

# QUASAR ELECTRONICS KIT No 1154

## ELECTRONIC EAVESDROPPING DEVICES DETECTOR

---

### General Description

The placement of electronic eavesdropping devices in homes and companies offices is becoming - unfortunately - a usual phenomenon through the passing of the years. Espionage movies admirers, is possible to remember scenes of the placement of very small components (which had the format of a button or a lentil) in rooms or offices which are not far away from the reality.

However, the detection of electronic eavesdropping devices is not so easy, even though it is known their placement. The reason is the very small format and their similarity to other things which we use every day.

Using the detector that is described in this article, you can ensure the privacy of your personal life because it allows you to sweep for electronic eavesdropping devices.

---

### Technical Specifications - Characteristics

Supply voltage: 9V(DC)

Dissipation current: 30mA (max)

Detection range: 1 - 1000 MHz

Acoustic indication using a loudspeaker

Sensitivity adjustment using a potentiometer

---

### How it Works

Electronic bugs are very small radio frequency transmitters, that are secretly placed in a room that is to be monitored. Since most bugs are RF sources, almost any wideband receiver can be used as a detector. Our detector detects an RF signal ranging from 1 to 1000 MHz. Figure 1 shows the schematic diagram of the detector.

When the electronic bug operates, it emits an RF signal. This signal is received by the antenna (point 1 of figure 1) and is applied to the base of the transistor TR1 through a high-pass filter ( a filter that permits the passing of high frequencies).

The high-pass filter consists of the capacitors C4, C5 and the resistor R7. When low frequency signals are applied to the input of the filter, the capacitors C4 and C5 operate as open switches and the filter rejects the low frequency signals. The cut-off frequency of the high-pass filter is defined to be 60 Hz rejecting any interference which comes from the mains.

The transistor TR1 is in common collector conjunction and it is used to amplify the signal. The gain that is provided is 10dB for a signal that varies in the frequency range 1 - 1000 MHz. The resistors R1, R2, R8 form the biasing network for the transistor TR1.

The amplified signal is then applied, via the capacitor C6, to the anode of the diode D1.

The diode is particularly manufactured to operate in high frequencies, since a common diode can not go from the conduction condition to the cut-off condition very fast preventing the appearance of reverse currents. However the operation of the diode in the high frequencies range results in the appearance of a conduction at the beginning of the negative half period.

The potentiometer P1 adjusts the proportion of the signal at the terminals of the diode D1 and applies it to the inverting input (pin 2) of the operational amplifier A1.

The operational amplifier A1 is configured as a very high gain amplifier. The value of the gain is defined by the capacitor C8 and the resistors R6 and R12.

With no signal input from the antenna, the output of A1 at pin 1 is near ground potential.

When the antenna detects a signal in the range 1 - 1000 MHz, it applies it to the base of the transistor TR1 producing a negative-going voltage at the cathode of diode D1. That voltage is applied to the inverting input of A1 which amplifies and inverts the signal, producing a positive-going output at pin 1.

The next stage after the op. amp. A1 is a voltage controlled oscillator (VCO). The oscillation frequency of VCO is controlled by the output voltage of the operational amplifier A1. The operational amplifiers A2, A4, along with the resistors R11, R13, R14, R16, R17, R18, R19, R20, R21, R23, the capacitor C9 and the transistor TR2 are arranged to form a voltage-controlled oscillator (VCO) that operates out of the audio-frequency range. As the output of A1 increases, the frequency of the VCO increases. The VCO output, at pin 8 of the operational amplifier A4, is fed to the input of A3, which is configured as a non-inverting unity gain (buffer) amplifier. The output of A3 is used to drive the transistor TR3, which, in turn, drives the output speaker.

---

## Construction

Before you start the construction of the circuit you must follow the basic instructions.

Place and solder the socket of the IC1. Then install the passive components (resistors, capacitors) on the board checking for the right placement and orientation. After this, install the semiconductors (diode, transistors, IC). You ought to be very careful in order to avoid the overheating of the IC's diodes and transistors terminals.

Place the IC1 on its base, checking for the right orientation. Use a 25W iron solder without using soldering flux.

When you have finished the structure of the circuit, check your work for the common construction errors (incorrectly orientated components, solder bridges, misplaced components), particularly where the transistors and diode are concerned.

Check if there are any dry joints. A proper joint is spread all over the pad and is shiny. A dry one is dull, bulky and has the shape of the ball.

If everything is correct, clean the printed circuit board using a proper spray.

Finally, install the board in a metal box connecting its chassis to the ground of the circuit (point 5).

Connect the speaker to the points 2 and 3, and the antenna to the point 1 (see figure 1). Use a 9V battery to supply the circuit. The clip of the battery is connected to the points 4 and 5. The red wire of the clip (positive/+) is connected to point 4, while the black one (negative/-) to point 5.

Afterwards, stand in the middle of the room you want to check. Adjust the potentiometer in order the sound coming from the loudspeaker LS to be slightly audible. You must do this in order the external electromagnetic fields to be ignored. Begin the detection of an RF signal

in the room. The loudspeaker will start to sound, when a signal in the frequency range (1 - 1000MHz) will be detected.

If the sound is keen, that means we are very close to the transmitter. Searching for the point where we have the highest frequency we can detect the position of the electronic bug.

Notice that, the sensitivity of the detector depends on the length of the antenna. An antenna of 20-40 cm length is proper for our detector.

---

## **Adjustments**

This kit does not need any adjustments, if you follow the building instructions.

---

## **Warning**

Quasar Electronics kits are sold as stand alone training kits.

If they are used as part of a larger assembly and any damage is caused, our company bears no responsibility.

While using electrical parts, handle power supply and equipment with great care, following safety standards as described by international specs and regulations.

If there are computers, fluorescent lamps, mobile phones or telephone exchanges in the place you want to check the existence of electronic eavesdropping devices you have to put them out of order, since the above devices can cause many serious problems to the detector.

---

## **If it does not work**

Check your work for possible dry joints, bridges across adjacent tracks or soldering flux residues that usually cause problems.

Check again all the external connections to and from the circuit to see if there is a mistake there.

- See that there are no components missing or inserted in the wrong places.

- Make sure that all the polarised components have been soldered the right way round. -

Make sure the supply has the correct voltage and is connected the right way round to your circuit.

- Check your project for faulty or damaged components.

If everything checks out and your project still fails to work, please contact us for information on our Get-You-Going service.

---

## Electronic Diagram

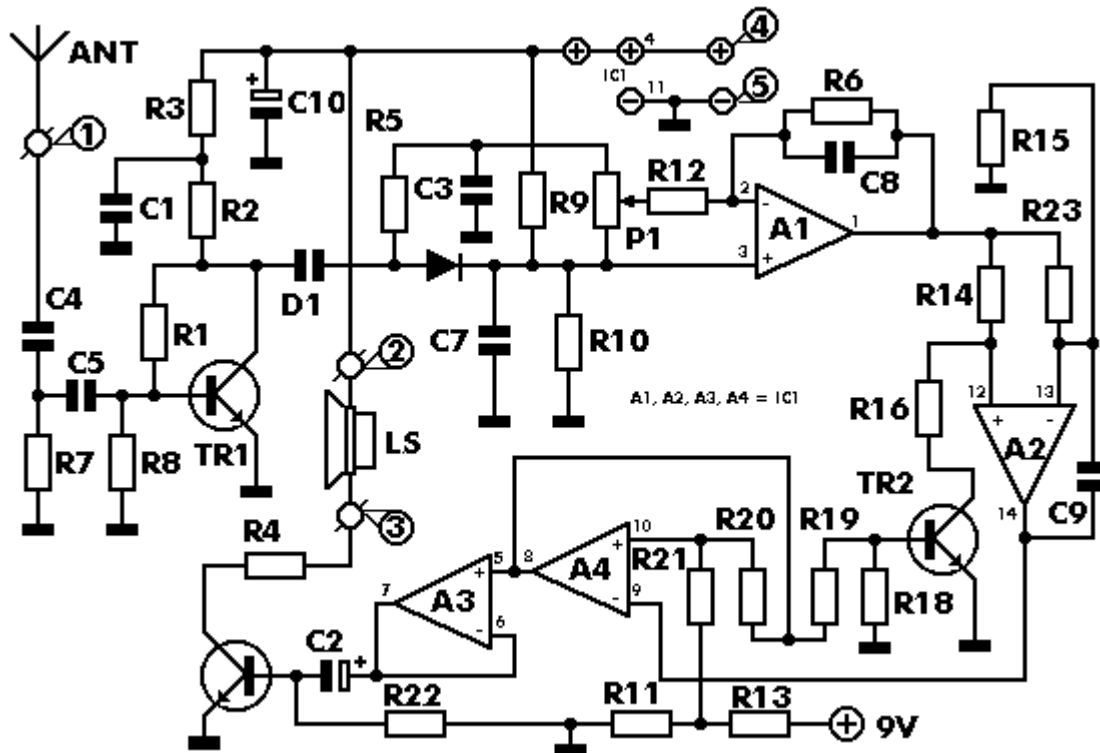

---

## Parts List

All components including printed circuit board, assembly instructions including schematics and detailed parts list are supplied when you purchase the kit.

---

## Ordering

For pricing info and online ordering please visit:

<http://www.quasarelectronics.com/1154.htm>

For further info please contact us by e-mail:

[mailto: sales@QuasarElectronics.com](mailto:sales@QuasarElectronics.com)

---

**COPYRIGHT** © 2003 Quasar Electronics Limited. All rights reserved. Reproduction of this document in whole or in part in any form or medium without express written permission of Quasar Electronics Limited is prohibited.

E&OE