

QUASAR ELECTRONICS KIT No. 1113

2x18 Watt POWER AMPLIFIER

General Description

This kit is a simple and reliable STEREO power amplifier. It has great input sensitivity, low distortion, good stability in operation, full protection against overloads and output short-circuits. It makes use of latest technology IC's to keep the size of the circuit small, without however sacrificing its quality.

Technical Specifications - Characteristics

(The specifications are for one channel) Input impedance:

Input sensitivity: 250 mV

Signal to noise ratio: 80 dB

Frequency response: 20 - 20,000 Hz +/- 1 dB

Distortion: 0.5 % maximum

Load impedance: 4 ohm minimum

Supply voltage: +/- 18 VDC

Current drawn: 2 A maximum

How it Works

The circuit is very simple thanks to the use of the integrated circuit TDA 2030 which is a complete audio amplifier. The IC includes the differential amplifier that is used to drive the on-chip power stage, the output stage and short-circuit and thermal shutdown circuits for protection. (See the diagram for the internal structure of the TDA 2030). As this is a STEREO amplifier only one channel is discussed here and the components in brackets belong to the other channel. The input signal is applied through the capacitor C1 (C9) to the non-inverting input (pin 1) of the IC. The resistor R1 (R6) biases the input at the correct voltage. The input of the amplifier consists of a differential amplifier for better linearity. The coupling between stages in the IC is direct to avoid the usual problems created by the use of coupling capacitors. Connected to the output there are two protection circuits which shut the circuit down if there is an overload, a short circuit in the output or an abnormal increase of its temperature. The output stage itself consists of two DARLINGTON pairs which give greater amplification with lower distortion, higher input impedance and better matching into low impedance loads (speakers). The diodes you see in the circuit diagram of the IC are there for added safety. The external components are used to control the circuit's frequency response and linearity within the audible spectrum. The capacitor C3 (C11) is for the decoupling of the inverting input of the IC (pin 2) and the resistor R2 (R7) controls the gain of the circuit in closed loop. Increasing its value, decreases gain and vice-versa. The network R3, R4 and C7 (R8, R9, C15) provides feed back and controls the cut-off frequency limits of the amplifier. The capacitors C2 (C10) and C4 (C12) are there to filter the supply voltage from hum and other noise. C5 (C13) and C6 (C16) block the unwanted

high frequencies which could cause instability to the circuit. The resistor R5 (R10) together with the capacitor C8 (C16) controls the frequency response and at the same time prevents any unwanted oscillations especially when the circuit is connected into inductive loads (speakers). Finally the two diodes D1 and D2 (D3 & D4) protect the circuit from sudden peaks of the output signal. The circuit needs a symmetrical power supply capable of delivering at least 18 VDC/3 A and can be connected to loads of 8 or 4 ohm.

Construction

First of all let us consider a few basics in building electronic circuits on a printed circuit board. The board is made of a thin insulating material clad with a thin layer of conductive copper that is shaped in such a way as to form the necessary conductors between the various components of the circuit. The use of a properly designed printed circuit board is very desirable as it speeds construction up considerably and reduces the possibility of making errors. Quasar Electronics Kit boards also come pre-drilled and with the outline of the components and their identification printed on the component side to make construction easier. To protect the board during storage from oxidation and assure it gets to you in perfect condition the copper is tinned during manufacturing and covered with a special varnish that protects it from getting oxidised and also makes soldering easier. Soldering the components to the board is the only way to build your circuit and from the way you do it depends greatly your success or failure. This work is not very difficult and if you stick to a few rules you should have no problems. The soldering iron that you use must be light and its power should not exceed the 25 Watts. The tip should be fine and must be kept clean at all times. For this purpose come very handy specially made sponges that are kept wet and from time to time you can wipe the hot tip on them to remove all the residues that tend to accumulate on it.

DO NOT file or sandpaper a dirty or worn out tip. If the tip cannot be cleaned, replace it.

There are many different types of solder in the market and you should choose a good quality one that contains the necessary flux in its core, to assure a perfect joint every time.

DO NOT use soldering flux apart from that which is already included in your solder. Too much flux can cause many problems and is one of the main causes of circuit malfunction.

If nevertheless you have to use extra flux, as it is the case when you have to tin copper wires, clean it very thoroughly after you finish your work. In order to solder a component correctly you should do the following:

Clean the component leads with a small piece of emery paper.

- Bend them at the correct distance from the component's body and insert the component in its place on the board.

- You may find sometimes a component with heavier gauge leads than usual, that are too thick to enter in the holes of the p.c. board. In this case use a mini drill to enlarge the holes slightly. Do not make the holes too large as this is going to make soldering difficult afterwards.

- Take the hot iron and place its tip on the component lead while holding the end of the solder wire at the point where the lead emerges from the board. The iron tip must touch the lead slightly above the p.c. board.

- When the solder starts to melt and flow, wait till it covers evenly the area around the hole and the flux boils and gets out from underneath the solder. The whole operation should not take more than 5 seconds. Remove the iron and leave the solder to cool naturally without blowing on it or moving the component. If everything was done properly the surface of the joint must have a bright metallic finish and its edges should be smoothly ended on the

component lead and the board track. If the solder looks dull, cracked, or has the shape of a blob then you have made a dry joint and you should remove the solder (with a pump, or a solder wick) and redo it. - Take care not to overheat the tracks as it is very easy to lift them from the board and break them.

- When you are soldering a sensitive component it is good practice to hold the lead from the component side of the board with a pair of long-nose pliers to divert any heat that could possibly damage the component.

- Make sure that you do not use more solder than it is necessary as you are running the risk of short-circuiting adjacent tracks on the board, especially if they are very close together.

- When you finish your work, cut off the excess of the component leads and clean the board thoroughly with a suitable solvent to remove all flux residues that may still remain on it.

The use of the TDA 2030 has simplified very much the circuit and reduced its dimensions to a minimum. Solder the pins, the resistors, the capacitors and the diodes on the board trying to do it in the same order as above. Watch the polarity of the electrolytic capacitors and make sure that the diodes are inserted the right way round. Make the jumper connection which is located between C2 and C11 on the board. Fit the IC's on the heatsink using the screws provided but do not tighten them yet. Insert the IC's carefully on the PCB and solder their pins without over heating them in the process, and when you have finished soldering tighten the screws as much as possible to ensure the efficiency of the heatsink. Using the self-tapping screws included in the kit secure the heatsink on the P.C. board to avoid damaging the IC's. Inspect your work very carefully and if you are satisfied with the work done so far make the following connections:

- 1 (signal) and 2 (common) LEFT input.
- 4 (+) and 5 (-) LEFT speaker
- 7 (signal) 8 (common) RIGHT input.
- 9 (+) and 10 (-) RIGHT speaker
- 3 (+18 V), 6 (-18 V) and 2 or 5 or 10 (common 0 V)

The connections to the inputs of the amplifier must be made with shielded cable to avoid oscillations and noise. A suitable power supply is the one shown in the circuit diagram below or any other capable of delivering at least $\approx 18\text{ V}/3\text{ A DC}$, with a good filter in the output to eliminate ripple and noise.

Adjustments

This kit does not need any adjustments, if you follow the building instructions.

Warning

Quasar Electronics kits are sold as stand alone training kits.

If they are used as part of a larger assembly and any damage is caused, our company bears no responsibility.

While using electrical parts, handle power supply and equipment with great care, following

safety standards as described by international specs and regulations.

If it does not work

Check your work for possible dry joints, bridges across adjacent tracks or soldering flux residues that usually cause problems.

Check again all the external connections to and from the circuit to see if there is a mistake there.

- See that there are no components missing or inserted in the wrong places.
- Make sure that all the polarised components have been soldered the right way round. - Make sure the supply has the correct voltage and is connected the right way round to your circuit.
- Check your project for faulty or damaged components.

If everything checks out and your project still fails to work, please contact us for information on our Get-You-Going service.

Electronic Diagram

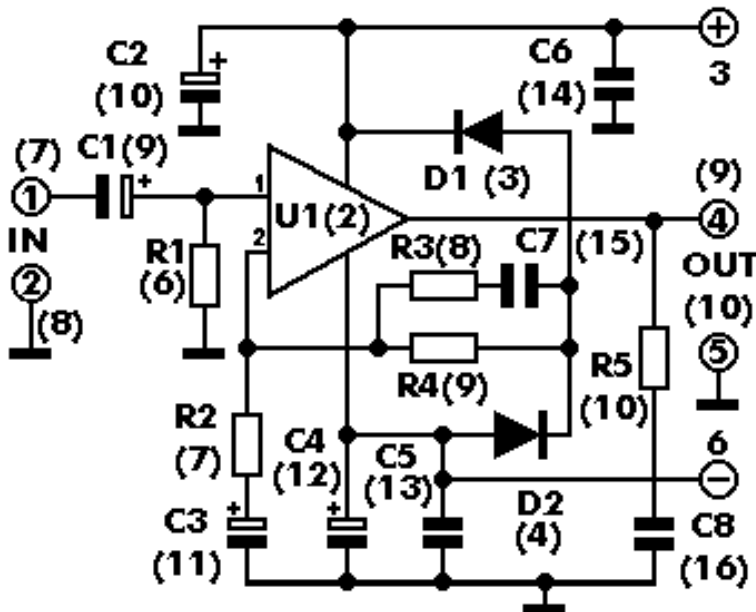

Parts List

All components including printed circuit board, assembly instructions including schematics and detailed parts list are supplied when you purchase the kit.

Ordering

For pricing info and online ordering please visit:

<http://www.quasarelectronics.com/1113.htm>

For further info please contact us by e-mail:

[mailto: sales@QuasarElectronics.com](mailto:sales@QuasarElectronics.com)

E&OE