

# QUASAR ELECTRONICS KIT No. 1093

## WINDSCREEN WIPER CONTROLLER

---

### General Description

This is a very useful accessory for any car. It can adjust the frequency of operation of the windscreen wipers between once a minute and once a second.

This is a very desirable feature that will prolong both the life of your wipers and of the windscreen as it will let you adjust the rate of operation of the wipers according to the prevailing weather conditions

---

### Technical Specifications - Characteristics

Working voltage: ..... 12-14 VDC

Maximum current: ..... 200 mA

Frequency of operation: ... 10-60 times/second

---

### How it Works

The circuit consists of an operational amplifier U1 which has a very high input impedance because it has a J-FET transistor in its input. This op-amp is a pin to pin replacement for the well known but old fashioned 741 and can be used in all these applications where it is necessary to have a low biasing current, high input impedance, low transfer time and extended bandwidth.

This IC is the LF351 and has the following specifications:

#### CHARACTERISTICS OF THE LF351 J-FET OP-AMP

Supply voltage: ..... +/- 18 V max.

Power dissipation: ..... 500 mW

Max. Input voltage: ..... +/- 15 V

Operating temperatures: ..... 0-70 °C

Max. Junction temperature: ..... 115 °C

Max. soldering temperature: ..... 300 °C for 10s

In this circuit the op-amp is used as a simple timer with adjustable delay time. The time is set by the potentiometer P1. The capacitor C2 charges through the resistor network R5, R4 and P1. The resistor R5 provides the closed loop feedback necessary to the non inverting input of the op-amp. As soon as the circuit is connected to a power supply the relay is energised and its contacts close. The capacitor C2 starts charging and when the voltage across it becomes equal to the potential existing in the other input (pin 3) the relay opens. After a while the capacitor starts charging again and the cycle is repeated. As you see the relay closes for a while, opens its contacts briefly, closes again and so on. The intervals of operation-pause can be adjusted by means of P2.

If the points 4 and 5 on the p.c. board are connected together with a switch then the circuit

closes the relay and it opens it immediately. This is very useful if we want the wipers to operate once and then stop for a while before the next operation.

---

## Construction

First of all let us consider a few basics in building electronic circuits on a printed circuit board. The board is made of a thin insulating material clad with a thin layer of conductive copper that is shaped in such a way as to form the necessary conductors between the various components of the circuit. The use of a properly designed printed circuit board is very desirable as it speeds construction up considerably and reduces the possibility of making errors. Quasar Electronics Kit boards also come pre-drilled and with the outline of the components and their identification printed on the component side to make construction easier. To protect the board during storage from oxidation and assure it gets to you in perfect condition the copper is tinned during manufacturing and covered with a special varnish that protects it from getting oxidised and makes soldering easier. Soldering the components to the board is the only way to build your circuit and from the way you do it depends greatly your success or failure. This work is not very difficult and if you stick to a few rules you should have no problems. The soldering iron that you use must be light and its power should not exceed the 25 Watts. The tip should be fine and must be kept clean at all times. For this purpose come very handy specially made sponges that are kept wet and from time to time you can wipe the hot tip on them to remove all the residues that tend to accumulate on it.

DO NOT file or sandpaper a dirty or worn out tip. If the tip cannot be cleaned, replace it. There are many different types of solder in the market and you should choose a good quality one that contains the necessary flux in its core, to assure a perfect joint every time. DO NOT use soldering flux apart from that which is already included in your solder. Too much flux can cause many problems and is one of the main causes of circuit malfunction. If nevertheless you have to use extra flux, as it is the case when you have to tin copper wires, clean it very thoroughly after you finish your work.

In order to solder a component correctly you should do the following:

- Clean the component leads with a small piece of emery paper.
- Bend them at the correct distance from the component's body and insert the component in its place on the board.
- You may find sometimes a component with heavier gauge leads than usual, that are too thick to enter in the holes of the p.c. board. In this case use a mini drill to enlarge the holes slightly. Do not make the holes too large as this is going to make soldering difficult afterwards.
- Take the hot iron and place its tip on the component lead while holding the end of the solder wire at the point where the lead emerges from the board. The iron tip must touch the lead slightly above the p.c. board.
- When the solder starts to melt and flow, wait till it covers evenly the area around the hole and the flux boils and gets out from underneath the solder. The whole operation should not take more than 5 seconds. Remove the iron and leave the solder to cool naturally without blowing on it or moving the component. If everything was done properly the surface of the joint must have a bright metallic finish and its edges should be smoothly ended on the component lead and the board track. If the solder looks dull, cracked, or has the shape of a blob then you have made a dry joint and you should remove the solder (with a pump, or a solder wick) and redo it.
- Take care not to overheat the tracks as it is very easy to lift them from the board and

break them.

- When you are soldering a sensitive component it is good practice to hold the lead from the component side of the board with a pair of long-nose pliers to divert any heat that could possibly damage the component.
- Make sure that you do not use more solder than it is necessary as you are running the risk of short-circuiting adjacent tracks on the board, especially if they are very close together.
- When you finish your work cut off the excess of the component leads and clean the board thoroughly with a suitable solvent to remove all the flux residues that still remain on it.

The construction of the controller is very easy and straight forward if you follow the instructions and the diagrams that come with the kit. First of all take all the components out of the packet and identify them. Solder the seven pins and the IC socket in their places on the board. The notch on the socket should be facing towards the power supply pins. Continue your work with the resistors and the capacitors, taking care with the capacitors to insert them correctly on the board as they have a positive and a negative pole which should be connected accordingly. Solder then in their places the relay, the potentiometer, the diodes and the transistor. The diodes should be inserted with the cathode towards the little white line in the outline of the component on the board and the transistor should be inserted with the flat side of its casing towards the straight line of its outline. At this point make a final visual inspection of the work done so far and if everything is OK clean the board carefully and insert the IC in its socket aligning the notch on its body with the notch on the socket.

The wiper controller is now ready to be tested and used.

Connect an ON-OFF switch between points 4 and 5. Points 2 and 3 are the contacts of the relay and should be connected in series with the motor of the wipers. Points 6 and 7 should be connected to the positive and negative poles of the car's electric circuit respectively after the wiper on off switch. (The wipers are going to be controlled by the relay and the wiper switch is now going to control the circuit.)

If you did everything properly the circuit should work as soon as you close the wiper switch of your car.

---

## **Adjustments**

This kit does not need any adjustments, if you follow the building instructions.

---

## **Warning**

Quasar Electronics kits are sold as stand alone training kits.

If they are used as part of a larger assembly and any damage is caused, our company bears no responsibility.

While using electrical parts, handle power supply and equipment with great care, following safety standards as described by international specs and regulations.

---

## If it does not work

Check your work for possible dry joints, bridges across adjacent tracks or soldering flux residues that usually cause problems.

Check again all the external connections to and from the circuit to see if there is a mistake there.

- See that there are no components missing or inserted in the wrong places.

- Make sure that all the polarised components have been soldered the right way round. -

Make sure the supply has the correct voltage and is connected the right way round to your circuit.

- Check your project for faulty or damaged components.

If everything checks out and your project still fails to work, please contact us for information on our Get-You-Going service.

---

## Electronic Diagram

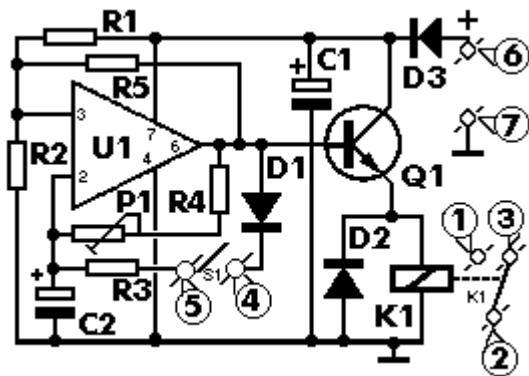

---

## Parts List

All components including printed circuit board, assembly instructions including schematics and detailed parts list are supplied when you purchase the kit.

---

## Ordering

For pricing info and online ordering please visit:

<http://www.quasarelectronics.com/1093.htm>

For further info please contact us by e-mail:

[mailto: sales@QuasarElectronics.com](mailto:sales@QuasarElectronics.com)

---

**COPYRIGHT** © 2003 Quasar Electronics Limited. All rights reserved. Reproduction of this document in whole or in part in any form or medium without express written permission of Quasar Electronics Limited is prohibited.

E&OE