

QUASAR KIT No 1081

LIQUID LEVEL DETECTOR

General Description

This is a simple but reliable circuit that has been designed for use in cases that the level of a liquid that is stored within a container, has to be monitored. The circuit is ideal for monitoring the presence, the absence or the level of water, or any other polar liquid. It may be used in automated drink dispensers, washing machines, irrigation systems, water and fuel tanks, burners, central heating, etc.

Technical Specifications - Characteristics

Supply voltage :220V AC
Operating voltage :8V DC
Current consumption :20mA
Relay load :250V/2A

How it Works

The circuit is based on the LM1830 integrated circuit.

The LM1830 is a monolithic bipolar integrated circuit which is specially designed for the detection of the presence, or absence, of liquids.

IC1, LM1830, produces an AC voltage at pin 13. This is used in order to drive two sensor pins which are submerged into the liquid whose level needs to be monitored.

The presence of the liquid is detected by an arrangement which is formed by using the sensor pins within a voltage divider circuit. The signal level is measured across the length of the sensor pins.

Integrated circuit IC2, is a quadruple CMOS analogue switch (N1 - N4). By using this IC, the circuit is able to provide a variable output level. This is used in order to set the minimum and maximum liquid level limits.

Switches N1 and N2 of integrated circuit IC2, open and close alternatively. A control signal that is issued by IC1 is used in order to drive them.

Switch N3 forms an inverter. This is done by connecting the input of the device to the ground. Its output is connected to the inputs of switches N1 and N2.

The outputs of these switches (N1 and N2), are used in order to drive pin 10 of integrated circuit IC1. Pin 10 is the input pin provided by integrated circuit IC1 for the connection of the sensor arrangement.

All control pins of switches N1 - N4 of integrated circuit IC2, are driven by pin 12 of integrated circuit IC1, which is the output pin of the LM1830 (IC1). Switch N4 is connected to this output and is used as a buffer between the output stage of the circuit and the output of IC1 (pin 12).

The output stage is formed by the transistor TR1 and the relay RL1. RL1 is able to drive loads

up to 250V/2A (loads like pumps, for example).

Construction

The assembly of the circuit is simple and easy, provided the basic rules of circuit assembly work, are followed.

Jumper J1 should be soldered, first.

The bases of integrated circuits IC1 and IC2 should be installed next. Make sure to observe the orientation shown at the PCB. layout diagram.

Proceed by installing the resistors, capacitors, diodes, transistor TR1, relay RL1 and the transformer T1. You are advised to install them in this order.

Wherever this applies, make sure to observe the correct orientation of the components. This is shown at the PCB. layout diagram.

You are advised to use a small soldering iron (up to 25W), together with good quality solder, but avoid using any soldering flux. Use the iron tip in order to heat both the soldering point and the component lead. Allow a small quantity of solder to be melted. A good quality joint is shiny and covers the whole area of the pad, after the iron tip is removed from the pad and the solder has cooled down. Paying a little extra attention at this point will save you from possible future problems during the operation of the circuit.

After finishing with all the soldering, check the printed circuit board in order to spot any short circuits, dry joints, misplaced components, or unsoldered leads.

If all the above are correct, then, the PCB. should be cleaned from the soldering residues by using a cleaning spray or acetone. The integrated circuits IC1 and IC2 should be installed on their bases. Their orientation should match the one shown on the PCB. layout diagram.

Adjustments

The sensor pins should be installed at the required maximum and minimum liquid levels of the tank, or container that is to be monitored.

The ground connection is installed on the base of the tank, or container. Alternatively, it may also be installed on the tank walls, provided they are made of a metallic, conductive, material. The maximum liquid level control pin is connected at point 7. The minimum liquid level control pin is connected at point 8, while the ground pin is connected at point 6.

Please, consult figure 2 in order to connect the output load (e.g. a pump) via the connection points 3 and 4. These are the relay connection points.

Connect the supply voltage (220 V AC) at points 1 and 2 of the PCB.

In the case that no one of the control pins is covered by the liquid in the container, the output pin (pin 12) of IC1 (LM1830), is driven to a low voltage level. In this case, the relay is released and the load is connected to the 220V supply.

As the liquid level rises within the tank, the maximum level control pin is covered by the liquid. As soon as this happens, the output of integrated circuit IC1 (pin 12), will be switched from a low voltage level to a high voltage level. The driving relay is thus energised and the load is disconnected from the 220 V AC supply. In the case of a pump, the relay would have switched it off by this point.

As mentioned above, analogue switch N3 is used as an inverter. Switch N2 controls the pin

monitoring the minimum liquid level limit, while switch N1 controls the pin monitoring the maximum liquid level limit. When the output of IC1 (pin 12), is high, N3 activates switch N2 and deactivates switch N1.

As soon as the liquid level falls below the level set by the minimum liquid level pin, the output of integrated circuit IC1 (pin 12) returns to a low level. The relay is thus deactivated and the load is connected to the supply again. In the case of a pump, this would imply that more liquid would be poured into the tank.

By repeating the sequence of events described in the preceding paragraphs, the liquid level may be maintained within the upper and lower liquid levels, as set by the two control pins. Taking the idea of controlling the liquid level within a tank, one step further, one can actually regulate the rate at which the tank is emptied. This is done by simply changing the connection of the relay RL1.

Warning

Quasar kits are sold as stand alone training kits.

If they are used as part of a larger assembly and any damage is caused, our company bears no responsibility.

While using electrical parts, handle power supply and equipment with great care, following safety standards as described by international specs and regulations.

If it does not work

Disconnect the supply voltage and read through the assembly instructions again. 1. Are there any dry joints?

2. Are there any short circuits?

3. Are all the wiring connections correct?

4. Are all the components installed the right way round?

5. Are all the component leads soldered properly?

If all the above have been checked and were found to be all right, or were fixed, then try to reconnect the power supply to the circuit. If it still doesn't work, then do not hesitate to call us.

Our technicians will be happy to solve any problems you might have relative to this kit.

If your project still fails to work, please contact us for information about our Get-You-Going service.

Schematic Diagram

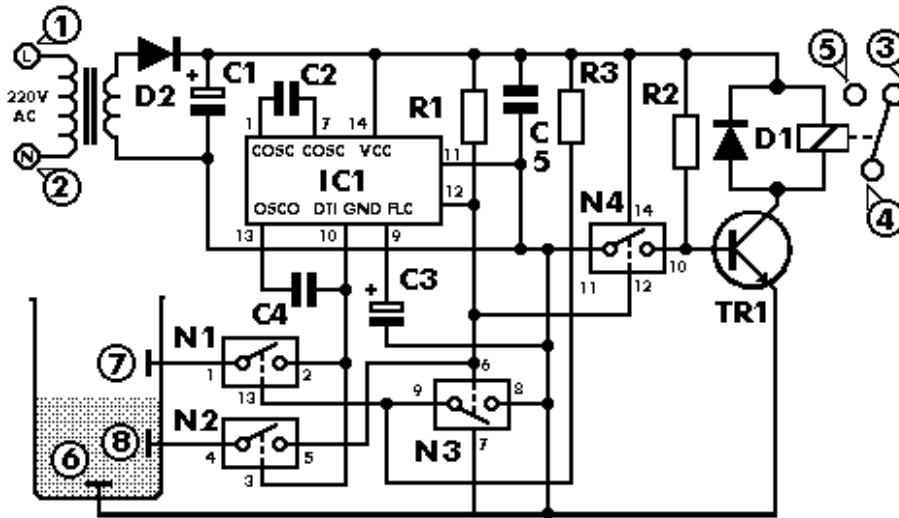

Parts List

All components including printed circuit board, assembly instructions including schematics and detailed parts list are supplied when you purchase the kit.

Ordering

For pricing info and online ordering please visit:

<http://www.quasarelectronics.com/1081.htm>

For further info please contact us by e-mail:

[mailto: sales@QuasarElectronics.com](mailto:sales@QuasarElectronics.com)

COPYRIGHT © 2003 Quasar Electronics Limited. All rights reserved. Reproduction of this document in whole or in part in any form or medium without express written permission of Quasar Electronics Limited is prohibited.

E&OE