

QUASAR ELECTRONICS KIT No. 1048

ELECTRONIC THERMOSTAT

General Description

A very simple but very useful project. Its purpose is to control the temperature of a device. It is far more accurate than its mechanical equivalent and has a much faster response to temperature variations which can be a very important feature if the device is used for overheat protection.

Very useful in power amplifiers to turn the fan on if the output transistors get too hot, in photographic laboratories to control the temperature of the baths, for freezers, aquariums etc.

As a sensor is used a special resistor the value of which changes with temperature.

Technical Specifications - Characteristics

Working voltage: 12-15V DC

Current: 50 mA

How it Works

The operation of the circuit is very simple. The operating conditions of the input transistor TR2 are set by the potential divider formed by R and R7. When the bias voltage at the base of TR2 is correct the transistor will be turned on and it will drive TR1 which in turn will drive TR3 and the relay will be energised. Any change to the value of R will change the ratio R/R7 and the voltage at their common end will also change. The relay will be energised at a certain temperature and will stay on as long as the sensor is at or above this temperature. The limit is determined by the setting of R7 and in order to adjust the circuit accurately you should conduct various tests using a thermometer to check the temperature at which the system gets activated.

The circuit is useful for temperatures between 20 and 70 degrees C. The working voltage of the thermostat is 9-12 VDC and the relay contacts can take up to 220 V/2 A.

Construction

First of all let us consider a few basics in building electronic circuits on a printed circuit board. The board is made of a thin insulating material clad with a thin layer of conductive copper that is shaped in such a way as to form the necessary conductors between the various components of the circuit. The use of a properly designed printed circuit board is very desirable as it speeds construction up considerably and reduces the possibility of making errors. Quasar Electronics Kit boards also come pre-drilled and with the outline of the components and their identification printed on the component side to make construction easier. To protect the board during storage from oxidation and assure it gets to you in perfect condition the copper is tinned during manufacturing and covered with a

special varnish that protects it from getting oxidised and also makes soldering easier. Soldering the components to the board is the only way to build your circuit and from the way you do it depends greatly your success or failure. This work is not very difficult and if you stick to a few rules you should have no problems. The soldering iron that you use must be light and its power should not exceed the 25 Watts. The tip should be fine and must be kept clean at all times. For this purpose come very handy specially made sponges that are kept wet and from time to time you can wipe the hot tip on them to remove all the residues that tend to accumulate on it.

DO NOT file or sandpaper a dirty or worn out tip. If the tip cannot be cleaned, replace it. There are many different types of solder in the market and you should choose a good quality one that contains the necessary flux in its core, to assure a perfect joint every time. DO NOT use soldering flux apart from that which is already included in your solder. Too much flux can cause many problems and is one of the main causes of circuit malfunction. If nevertheless you have to use extra flux, as it is the case when you have to tin copper wires, clean it very thoroughly after you finish your work.

In order to solder a component correctly you should do the following:

- Clean the component leads with a small piece of emery paper.
- Bend them at the correct distance from the component's body and insert the component in its place on the board.
- You may find sometimes a component with heavier gauge leads than usual, that are too thick to enter in the holes of the p.c. board. In this case use a mini drill to enlarge the holes slightly. Do not make the holes too large as this is going to make soldering difficult afterwards.
- Take the hot iron and place its tip on the component lead while holding the end of the solder wire at the point where the lead emerges from the board. The iron tip must touch the lead slightly above the p.c. board.
- When the solder starts to melt and flow wait till it covers evenly the area around the hole and the flux boils and gets out from underneath the solder. The whole operation should not take more than 5 seconds. Remove the iron and allow the solder to cool naturally without blowing on it or moving the component. If everything was done properly the surface of the joint must have a bright metallic finish and its edges should be smoothly ended on the component lead and the board track.
- If the solder looks dull, cracked, or has the shape of a blob then you have made a dry joint and you should remove the solder (with a pump, or a solder wick) and redo it.
- Take care not to overheat the tracks as it is very easy to lift them from the board and break them.
- When you are soldering a sensitive component it is good practice to hold the lead from the component side of the board with a pair of long-nose pliers to divert any heat that could possibly damage the component.
- Make sure that you do not use more solder than it is necessary as you are running the risk of short-circuiting adjacent tracks on the board, especially if they are very close together.
- When you finish your work cut off the excess of the component leads and clean the board thoroughly with a suitable solvent to remove all flux residues that may still remain on it.

The construction of the thermostat is very easy if you follow the instructions and the circuit diagram carefully. The connection pins and the relay should be soldered first of all followed by the resistors. To identify the resistors use the colour code. The colour bands for each value used are printed by the listing of the resistor in the parts list. After the resistors you should solder the diode and the transistors in their places on the p.c. board. Take care with the semiconductors as excess heat during soldering can easily destroy them.

When you finish construction check everything carefully for construction mistakes and then connect points 1 (+) and 2 (-) of the circuit across a power supply of 9-12 VDC. If the relay stays closed after power up warm up the sensor slightly and you should hear the relay click closed. If you leave the sensor to cool the relay should click again after a little while an indication that the circuit is working properly.

With the relay used you have two choices, normally open and normally closed contacts for different applications. The relay contacts are points 3,4 and 5 of the p.c. board. The heat sensitive resistor should be mounted on the device that the circuit is going to monitor its temperature and for this purpose this component comes in a special metal casing with a bolt and nut in one end to make mounting easier.

Adjustments

This kit does not need any adjustments, if you follow the building instructions.

Warning

Quasar Electronics kits are sold as stand alone training kits.

If they are used as part of a larger assembly and any damage is caused, our company bears no responsibility.

While using electrical parts, handle power supply and equipment with great care, following safety standards as described by international specs and regulations.

If it does not work

- Check your work for possible dry joints, bridges across adjacent tracks or soldering flux residues that usually cause problems.
- Check again all the external connections to and from the circuit to see if there is a mistake there.
- See that there are no components missing or inserted in the wrong places.
- Make sure that all the polarised components have been soldered the right way round.
- Make sure that the supply has the correct voltage and is connected the right way round to your circuit.
- Check your project for faulty or damaged components.

If your project still fails to work, please contact us for information about our Get-You-Going service.

Electronic Diagram

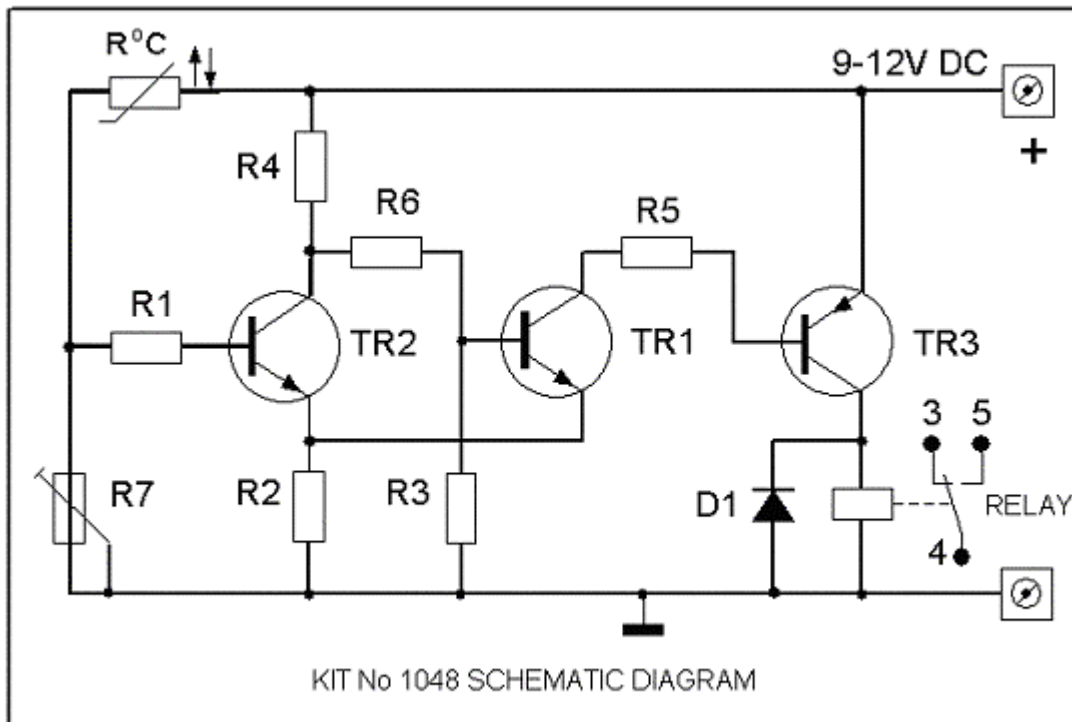

Parts List

All components including printed circuit board, assembly instructions including schematics and detailed parts list are supplied when you purchase the kit.

Ordering

For pricing info and online ordering please visit:

<http://www.quasarelectronics.com/1048.htm>

For further info please contact us by e-mail:

[mailto: sales@QuasarElectronics.com](mailto:sales@QuasarElectronics.com)

COPYRIGHT © 2003 Quasar Electronics Limited. All rights reserved. Reproduction of this document in whole or in part in any form or medium without express written permission of Quasar Electronics Limited is prohibited.

E&OE