

KIT 1031 – 25 WATT FM TRANSMITTER WITH 5 STAGES & VARICAP MODULATION

IMPORTANT: Please follow the instructions below carefully to avoid damaging the transmitter. All units are pre-tested - NO returns. If in doubt please contact our Technical Department for assistance BEFORE proceeding because it will be too late after.....

CAUTION: NEVER operate the transmitter without connecting a suitable antenna or dummy 50 Ohm load to the output otherwise there is a serious danger of destruction of the output stage of the transmitter.

DESCRIPTION - This is a powerful FM transmitter with 5 RF stages for greater stability and trouble free operation. The final output transistor is a Philips BLY 89 that delivers 25 Watts on the air. Modulation is achieved by using a varicap diode in the first RF stage for even better results. Like all of the high-power transmitter kits in this series, it comes pre-assembled and you only have to make the external connections and the adjustments for the desired frequency.

TECHNICAL SPECIFICATIONS

Modulation type:	FM
Frequency:	88-108 MHz
Output power:	25 Watts
Power Supply:	12-14V DC / 5.0A
Preamplifier	Kit 1052
Power Supply:	1056 or 1171
PCB:	70x220mm

CONNECTIONS - Firstly, fasten the heatsink to the underside of the PCB using the threaded post of the BLY89C transistor (do NOT over tighten the nut). Next check that none of the board components have been bent out of position in transit. In particular check the transistors TR1 & TR3 are vertical and their leads are not shorting. Also check that none of the coil turns are touching and are evenly spread. Realign them as necessary.

The connections to and from the PCB are few and simple. Note that the underside (heatsink side) of the PCB is the ground plane. Refer to the schematic and PCB layout diagrams overleaf and proceed as follows.

AUDIO INPUT - the audio input from a mixer or preamplifier (kit [1052](#) is suitable) should be connected using shielded cable. The centre (signal) is connected to the point marked AUDIO INPUT and the outer shield (ground) goes to ground plane (underside of the PCB). The potentiometer (P1) provides adjustment of the AF input level for a wide variety of input sources.

ANTENNA - The antenna can be a 50 Ohm Open Dipole, Ground Plane, 5/8 or YAGI. Connect it to the PCB at the point marked ANT using 50 Ohm coax cable. The centre conductor of the cable goes to the pad where C23 and C24 meet. The shield goes to the other side of C24 (i.e. the ground plane).

POWER SUPPLY - connect a 12-14VDC power supply rated 5A minimum (kit [1056](#) is suitable) to the two points marked (+) and (-). These are the pads that C20 straddles.

ALIGNMENT - To change the transmitting frequency of your transmitter, follow these instructions carefully.

1. Connect an SWR meter (RF Power Meter) between the transmitter output and the antenna.
2. Connect the power supply to the PCB terminals marked '+' and '-'.
3. Adjust the to the desired transmitting frequency using C6 variable capacitor. **TAKE CARE** when adjusting any of the variable capacitors, as they are brittle and will break easily.
4. Adjust the variable capacitors C14, C15, C18, C19, C23 and C24 in sequence so that maximum power reading is given by the SWR meter.
5. Use the R1 trimmer to adjust the modulation to the desired level.
6. Repeat this process a few times to fine tune the transmitter.

TRANSMITTERS AND THE LAW - It is against the law to transmit a radio signal without an appropriate license or with equipment that is not approved for use in the UK by the Radio Communications Agency (RCA). This transmitter has NOT been approved by the RCA.

Quasar Electronics, it's owners, and employees accept no responsibility whatsoever for any consequences arising from the use or misuse of unlicensed or unapproved equipment. If you live outside the UK we suggest that you check local laws before operating or purchasing transmitting equipment. Again, it is your responsibility not to break the law.

QUASAR ELECTRONICS LIMITED

PO Box 6935 BISHOP'S STORTFORD CM23 4WP UNITED KINGDOM

TEL: +44 (0)870 246 1826

FAX: +44 (0)870 460 1045

EMAIL: sales@quasarelectronics.com

WEBSITE: www.quasarelectronics.com



KIT 1031 – 25 WATT FM TRANSMITTER WITH 5 STAGES & VARICAP MODULATION

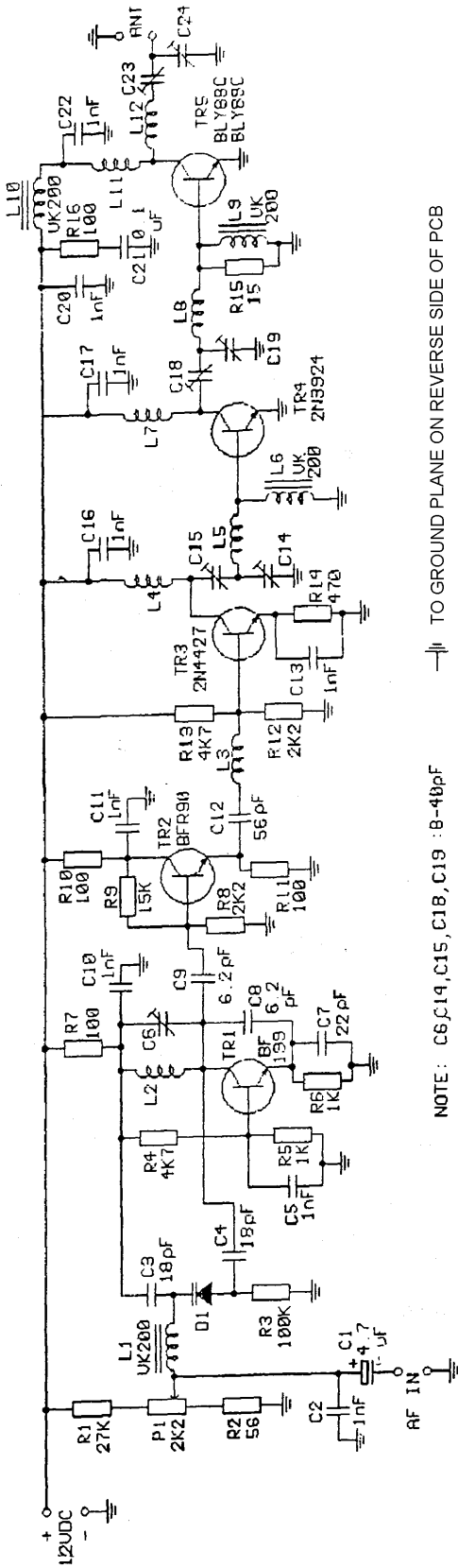

NOTE: C6, C14, C15, C18, C19 : 8-40pF
 C23, C24: 40-100pF
 TO GROUND PLANE ON REVERSE SIDE OF PCB

KIT NO 1021-1031

Solder power, audio and aerial cable directly to the solder pad points indicated below taking care not to dislodge surrounding components.

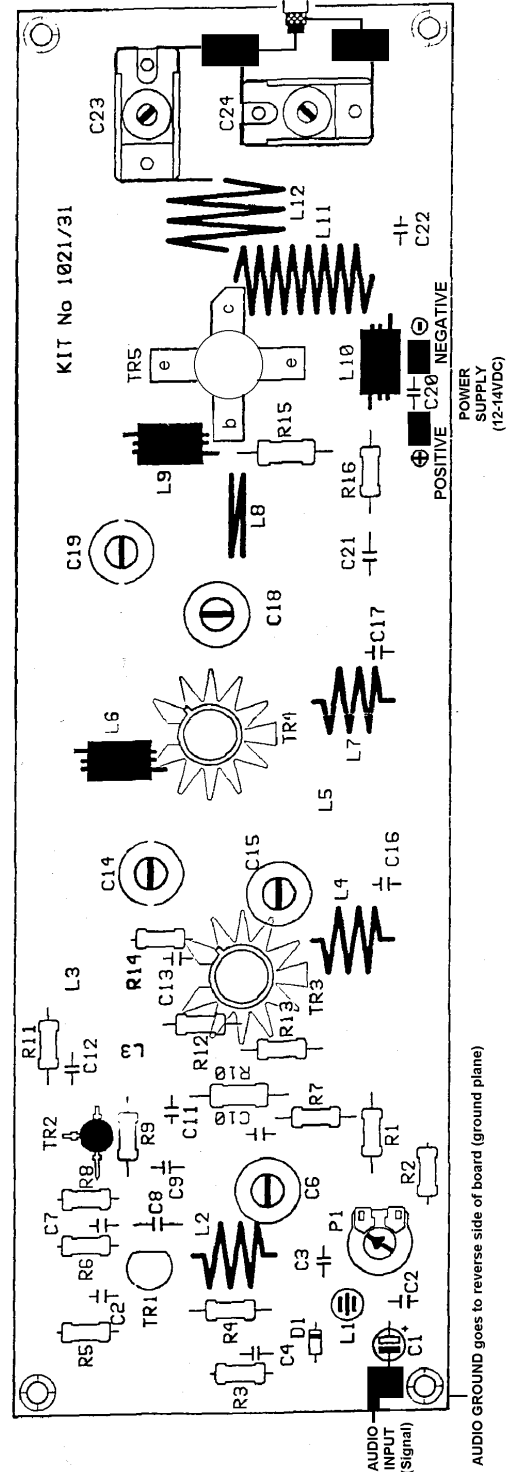

PLEASE NOTE: Actual PCB may be the mirror image of the picture on the right.

QUASAR ELECTRONICS LIMITED

PO Box 6935 BISHOP'S STORTFORD CM23 4WP UNITED KINGDOM

TEL: +44 (0)870 246 1826 FAX: +44 (0)870 460 1045

EMAIL: sales@quasarelectronics.com WEBSITE: www.quasarelectronics.com

