

## QUASAR KIT No. 1011

### MOTORBIKE ALARM (6V and 12VDC versions available)

---

#### General Description

A project that will protect your dear motorbike from theft or malicious damage. It uses a vibration sensor that will trigger the alarm at even the slightest disturbance if it is correctly adjusted. The circuit has an adjustable alarm duration and resets automatically after each alarm. It has a very small size and can easily be concealed on any type of motorbike.

---

#### Technical Specifications – Characteristics

Working voltage: 6 or 12 VDC (depending on the version purchased)

Max. current: 100 mA

---

#### How it Works

The circuit of the alarm is very simple as it is designed around an integrated circuit the CD 4093 that does almost every thing. When the contacts of the vibration sensor (S1) close even for a very short time the timer is started and the transistor TR1 is turned ON. The collector current of the transistor flows through the relay and closes its contacts. If there is a siren, the motorbike's horn, the lights or any other device connected to the alarm it will start working. After approximately 60 seconds the timer stops and the circuit returns to its original state. If you wish to reset the alarm before the timer has finished counting you must connect point 1 in the circuit with the negative supply rail.

---

#### Construction

First of all let us consider a few basics in building electronic circuits on a printed circuit board. The board is made of a thin insulating material clad with a thin layer of conductive copper that is shaped in such a way as to form the necessary conductors between the various components of the circuit. The use of a properly designed printed circuit board is very desirable as it speeds construction up considerably and reduces the possibility of making errors. Quasar Kit boards also come pre-drilled and with the outline of the components and their identification printed on the component side to make construction easier. To protect the board during storage from oxidation and assure it gets to you in perfect condition the copper is tinned during manufacturing and covered with a special varnish that protects it from getting oxidised and makes soldering easier. Soldering the components to the board is the only way to build your circuit and from the way you do it depends greatly your success or failure. This work is not very difficult and if you stick to a few rules you should have no problems. The soldering iron that you use must be light and its power should not exceed the 25 Watts. The tip should be fine and must be kept clean at all times. For this purpose come very handy specially made sponges that are kept wet and from time to time you can wipe the hot tip on

them to remove all the residues that tend to accumulate on it. DO NOT file or sandpaper a dirty or worn out tip. If the tip cannot be cleaned, replace it. There are many different types of solder in the market and you should choose a good quality one that contains the necessary flux in its core, to assure a perfect joint every time.

DO NOT use soldering flux apart from that which is already included in your solder. Too much flux can cause many problems and is one of the main causes of circuit malfunction. If nevertheless you have to use extra flux, as it is the case when you have to tin copper wires, clean it very thoroughly after you finish your work. In order to solder a component correctly you should do the following:

Clean the component leads with a little piece of emery paper - Bend them at the correct distance from the component body and insert the component in its place on the board.

Take the hot iron and place its tip on the component lead while holding the end of the solder wire at the point where the lead emerges from the board. The iron tip must touch the lead slightly above the p.c. board.

When the solder starts to melt and flow wait till it covers evenly the area around the hole and the flux boils and gets out from underneath the solder. The whole operation should not take more than 5 seconds. Remove the iron and let the solder to cool naturally without blowing on it or moving the component. If everything was done properly the surface of the joint must have a bright metallic finish and its edges should be smoothly ended on the component lead and the board track. If the solder looks dull, cracked, or has the shape of a blob then you have made a dry joint and you should remove the solder (with a pump, or a solder wick) and redo it.

Take care not to overheat the tracks as it is very easy to lift them from the board and break them.

When you are soldering a sensitive component it is good practice to hold the lead from the component side of the board with a pair of long-nose pliers to divert any heat that could possibly damage the component.

Make sure that you do not use more solder than it is necessary as you are running the risk of short-circuiting adjacent tracks on the board, especially if they are very close together.

After having finished your work cut off the excess of the component leads and clean the board thoroughly with a suitable solvent to remove all the flux residues that may still remain on it.

As you see the circuit is very simple using only few components and there shouldn't be any difficulties in building the project. You start construction by placing and soldering the connection pins and the IC socket. Continue with the resistors and the capacitors taking care not to insert the electrolytic the wrong way round as they are polarised and if they are connected in reverse they will be damaged. Now you can solder the diodes the LED and the transistor in their places on the p.c. board taking care not to overheat them and to insert them the right way round. After you have finished soldering the components you have to assemble the sensor on the board. Please follow the diagram care fully as the success of the project depends greatly on the correct assembly of the vibration sensitive switch. When you assemble the sensor tighten the adjustment screw up to a point that the loaded moving metal tongue is still free and the contacts are only slightly apart. In this position even a slight movement of the device will make the contacts close. Leave for the time being the sensor alone as you are going to complete the adjustments under power. Now is the time to insert the IC in its socket. The IC is a CMOS type and is very easily damaged by static discharges. This is the reason why it is supplied wrapped in aluminium foil. Even a static discharge from your body can damage it so please avoid touching its pins with your hands. To insert the IC is preferable to ground the circuit AND your body and then insert the IC trying to avoid touching

its pins. Apparently there is not such a great problem once the component is in its place as the external components seem to take the discharges before they can cause any damage to it. Needless to say that you must take care not to bend any pins during insertion and to put it the right way round.

The alarm should be connected to the battery of your motor bike BEFORE the ignition switch and must be provided with some means to activate it. (A lock switch concealed in some place of the bike will do nicely.) The supply must be connected at the points 2 (+) and 6 (-) of the circuit and the siren or any other warning device you want to use with it should be connected in series with the relay contacts 3,4 & 5. Number 4 is the moving contact. At any moment there is an open and a closed switch depending which other contact you choose to work with. If you want to be able to reset the alarm before the preset alarm time has passed then you should provide some means of connecting the point 1 of the circuit with the negative supply rail. There are lock switches with two different circuits at different positions of the key that could be used for this purpose, and is a matter of personal preference how the alarm is going to be installed.

---

## Adjustments

Now comes the most rewarding moment, when you will see your project at work. If everything was done correctly, and after making one final visual inspection for possible short circuits, flux residues on the board, misplacement of components etc. you can connect your alarm to a battery or a suitable power supply. You don't have to connect a siren at this stage.

- Be sure that you fit the sensor correctly and the contact is well soldered.
- Take a small 6 or 12 Volt lamp and make the connections:
- Bridge pins 2 and 4 on the PCB. This provides the circuit power supply to the relay common contact.
- Connect the lamp at pins No 5 and 6 of PCB. (When you supply the circuit the bulb must not lit).
- Bend the sensor blade to NOT touch the contact on the PCB.
- With the sensor screw adjust the distance (small distance is for maximum sensitivity long distance is for poor sensitivity).
- Now you can supply the circuit. Look at your watch. After the supply voltage application you MUST WAIT for 25 seconds and the circuit sensor MUST NOT CLOSE. This is the exit time and is intended to provide sufficient time for you to lock motorbike up.
- After 25 seconds move the sensor.
- You see the led light when the sensor is closed.
- The relay closes the contacts 4 and 5 the power supply goes to the lamp and it lights.
- The lamp will remain lit for 35 seconds (this is the siren working time – the alarm time).
- After 35 seconds the lamp will turn off and the circuit remains for the next triggering.

After all these tests remove the jumper from pins 2 and 4 take off the lamp and connect the siren you want. The + of siren's MUST connect to the pin 5. At the pin No 4 you connect the siren's power supply (+). So when the relay is armed the point 4 and 5 will join and the (+) of power supply will go to the siren's (+) terminal. The (-) terminal of siren must connect to the (-) of PCB (pin No 6).

If you connect the pin No 1 to the ground you can stop the alarm (RESET).

For better help look at the explanations diagram.



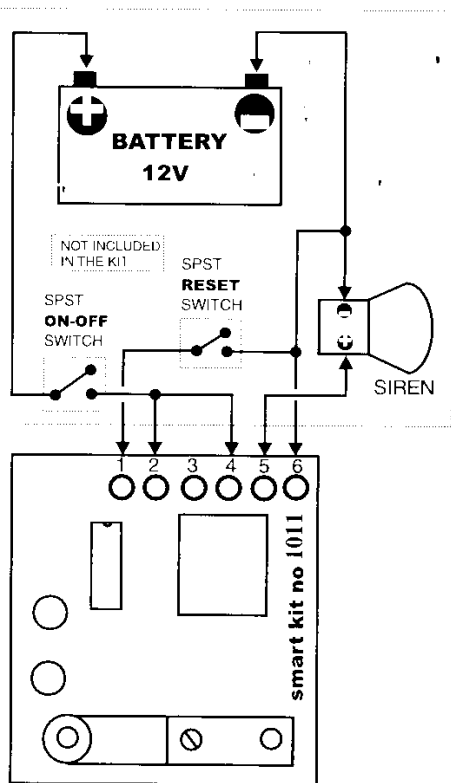

CONNECTION DIAGRAM

## Parts List

All components including printed circuit board, assembly instructions including schematics and detailed parts list are supplied when you purchase the kit.

## Ordering

For pricing info and online ordering please visit:

<http://www.quasarelectronics.com/1011.htm>

For further info please contact us by e-mail:

[mailto: sales@QuasarElectronics.com](mailto:sales@QuasarElectronics.com)

**COPYRIGHT** © 2008 Quasar Electronics Limited. All rights reserved. Reproduction of this document in whole or in part in any form or medium without express written permission of Quasar Electronics Limited is prohibited.

E&OE