

# 3180V3. ROLLING CODE 4-CHANNEL UHF REMOTE CONTROL

## General Guidelines for Electronic Kits and Assembled Modules

Thank you for choosing one of our products. Please take some time to carefully read the important information below concerning use of this product. The assembly and operating instructions are on the following pages.



### WEEE Directive (Waste Electrical and Electronic Equipment)

#### Notice To All European Union Citizens. Important environmental information about this product.

The crossed out wheeled bin symbol on this product, package or documentation indicates that disposal of this product after its lifecycle could harm the environment. Do not dispose of this product (or batteries if used) as unsorted municipal waste. It should be disposed by a specialized company for recycling.

The unit should be returned to your distributor or to a local recycling service. Please respect the local environmental rules. If in doubt contact your local authorities about waste disposal rules.

### Safety: General rules concerning safe use of our Kits or Modules.

**To ensure your safety, please observe these safety measures. In no way are these complete. As safety requirements vary, please check with your local authorities, in order to comply with local requirements. If in doubt, seek the help of a qualified person.**

**Battery or wall-adaptor operated devices are safe devices. They do not require special attention unless mains voltage is connected to an output e.g. a relay.**



To ensure electrical safety, and also protection from fire or personal injury, make sure your mains operated equipment complies with these safety hints:

- Use a suitable plastic enclosure. If a metal enclosure is used, make sure it is properly earthed.
- Use a power switch if the device consumes more than 10W. Use a double pole switch for mains operated, transformer-less kits.
- Mount a fuse in series with the mains switch. Use a slow blow (T) 50mA fuse for transformers up to 10W and a 100mA fuse for transformers up to 20W.
- Use a mains input connector, or a robust power cord with a clamp.
- Internal wiring carrying mains voltages must have a minimum cross-sectional area of 0.5mm<sup>2</sup>.

If supplied, attach the power rating label near the power cord of the device and fill-out the mains voltage, frequency, power consumption and fuse values.

## Troubleshooting and Support

90% of non working kits are due to poor soldering.

We operate a Get-You-Going service for non-working kits but there is a charge based on the time and components needed to complete the repair. Quite often it is not economically viable for us to repair and it is cheaper to supply a new ready made product at full cost.

## Disclaimer

Quasar Electronics reserves the right to change product specifications or to discontinue products without notice. Quasar Electronics cannot be held responsible for any loss or damage, direct or indirect, which might occur from the use of a product. Quasar Electronics Kits or Modules are intended for educational and demonstration purposes only. They are not intended for use in commercial applications. If they are used in such applications the purchaser assumes all responsibility for ensuring compliance with all local laws. In addition, they are not suitable for use as or as a part of life support systems, or systems that might create a hazardous situation of any kind.

## 3180V3. ROLLING CODE 4-CHANNEL UHF REMOTE CONTROL with RESET ON EACH CHANNEL

This kit is a significant improvement on a kit which was published in the Australian electronics magazine *Silicon Chip* in 7/2002. Please read this article as background. You can get it from <http://www.quasarelectronics.com/zip/3180.zip>

The main addition is that we have added Reset to each channel when in **TOGgle** mode. Thus for example, a garage door motor could be started when the **TOGgle** relay is activated then it will automatically cut off when the door has travelled its full movement and it hits a switch which resets / turns off the corresponding relay. The user does not have to stand watching the door then press the button on the transmitter unit again when he thinks it has open 'enough'. We have also replaced the individual transistors of the original circuit by a ULN2003A IC.

Up to 15 Transmitter units can be learnt by one Rx unit. (The article says 16 but the technical manual says 15.) To electronically connect the Tx unit with the receiver board press button 1 (the button all by itself) while **simultaneously** pressing the **LEARN** tact switch on the main board. You only have to do this briefly for under a second. But note it takes about **15 seconds** for the two units to internally connect and recognize each other. (During this 15 seconds it seems that one and only one keypress of the Tx unit will be recognised. Just disregard this. Wait the full 15 seconds until the two units have connected. Do not press the LEARN button again. Just wait 15 seconds.)

Tx units attached to any Rx unit can be electronically **unattached** by pressing the LEARN button continuously for 8 seconds. The **VALID DATA** LED is on during these 8 seconds. As soon as the LED goes off then you know that all Tx units previously recognized by the Rx unit have now been unattached from the Rx unit. If you want more details about the Microchip technology behind these Tx & Rx's you can get details at <http://www.quasarelectronics.com/ds.htm>. Technical details about the Automicro devices can be found on this page (file name AUTOMICRO.PDF)

**Relay Outputs:** Each output is rated to switch resistive loads of up to 240Vac or 28Vdc @ 5A maximum.

**WARNING: Mains voltages can be lethal! Board must be housed in a suitable isolating enclosure. Construction, installation, testing and commissioning should only be attempted by competent persons and in accordance with all local regulations. Ensure antenna wire cannot short to mains.**

We sell Tx and Rx units separately as 30A16-Tx and 30A16-Rx. See our website for details:

<http://www.quasarelectronics.com/30a16.htm>

**Assembly.** See **Components** listing below. Follow the overlay. Be careful on R3 & R5, do not put one leg in the small via hole by mistake!

Email [support@quasarelectronics.com](mailto:support@quasarelectronics.com) if you have any problems.

COMPONENTS		
Resistors 5% 1/4W carbon:		
1K	R13 brown black red	1
2K2	R9 R10 R11 R12 red red red	4
1M	R2 R4 R6 R8 brown black green	4
10M	R1 R3 R5 R7 brown black blue	4
1N4004	D1	1
100nF	C1 2 3 4 5 6 7 8 10 11	10
100uF/16V	ecap C9	1
4013	IC1 IC2	2
ULN2003A	IC3	1
7805	IC4	1
14 pin IC socket		2

16 pin IC socket	1
3 pin SIL header LK1 LK2 LK3 LK4	4
Jumpers	4
LED 3MM green L5	1
LED 5MM red L1 L2 L3 L4	4
12 volt relay RL1 RL2 RL3 RL4	4
Zippy tact switch PB1	1
2 pole t/block ED	1
3 pole t/block ED	2
3 pole t/block EK	4
17cm aerial wire	1
4 button Tx unit 4312RSA(O1)	1
Receiver module 3302D4-15(2A1)	1
3180V3 PCB	1

# GENERAL RELAY INFORMATION

## Warning! Risk of Electric Shock!

This information concerns kits and modules with relay outputs. TO USE THE RELAY OUTPUTS SAFELY YOU MUST OBSERVE THE MAXIMUM VOLTAGE AND CURRENT LIMITS QUOTED IN THE **PRODUCT DOCUMENTATION** (this is because the board design may not be rated to switch the maximum voltage and current limits printed on the relay itself or specified in the relay manufacturer's data sheet).

Controlling mains equipment with relay outputs must be treated with extreme caution. Electric shocks can cause severe and permanent injury or even death. Construction, installation, testing and commissioning should only be attempted by suitably qualified persons, or under the supervision of a suitably qualified person. These products are not suitable for children. Before connecting mains powered equipment to the relay outputs please check with the relevant authorities in order to ensure compliance with all current safety regulations. Many areas of the assembly may operate at mains voltage. A suitable isolating enclosure must be used. Exposed screw terminal blocks on some products must be insulated to prevent contact with exposed metallic parts at mains potential. Connected equipment should be suitably fused.

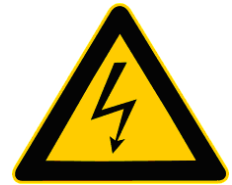

You will find relay outputs on many of the kits and modules that we sell. A relay is an electrically operated on/off switch. The voltage and current limits specified in the product documentation generally relate to resistive or light inductive loads.

## Relay Terminals

Most boards have SPDT (Single Pole Double Throw) style relays. These have three outputs:

**C** = Common

**NO** = Normally-Open contacts connect the circuit when the relay is activated; the circuit is disconnected when the relay is inactive. It is also called a Form A contact or "make" contact.

**NC** = Normally-Closed contacts disconnect the circuit when the relay is activated; the circuit is connected when the relay is inactive. It is also called a Form B contact or "break" contact.

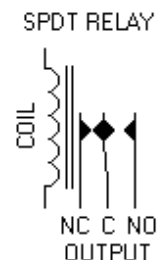

## Connecting the Device you want to Control

You must provide an external power source to the device you want to control. No voltage is present at the relay terminals (remember it is just a switch). The relay is normally connected in *series* with the positive (+) power wire of the device you want to control.

In this case, the positive wire from the power source should be connected to Common. Then either the NO or NC terminal (as appropriate for your purpose) is connected to the positive (+) wire going to the device you want to control. The negative (-) wire does not connect to the relay at all. It goes directly from the power source negative output to the device negative (-) terminal.

## Typical SPDT Relay Connection Diagrams

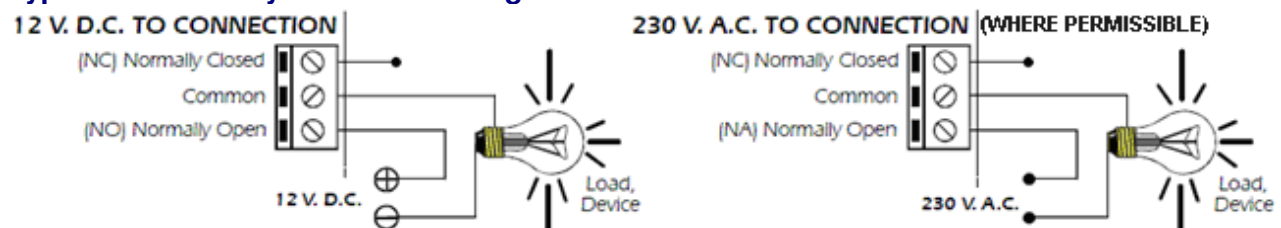

## Anti-Spark SPDT Relay Connection Diagram

Sometimes the connected equipment can cause arcing across the relay contacts. This must be corrected by installing a resistor and capacitor (not supplied) between the two contacts of the relay as shown below. Component values are for 230Vac mains.

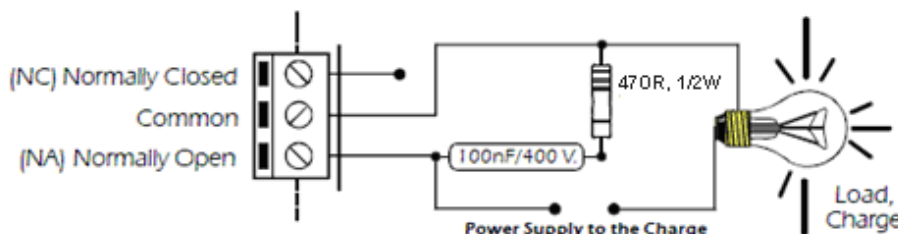

# 3180V3. ROLLING CODE 4-CHANNEL UHF REMOTE CONTROL with RESET ON EACH CHANNEL

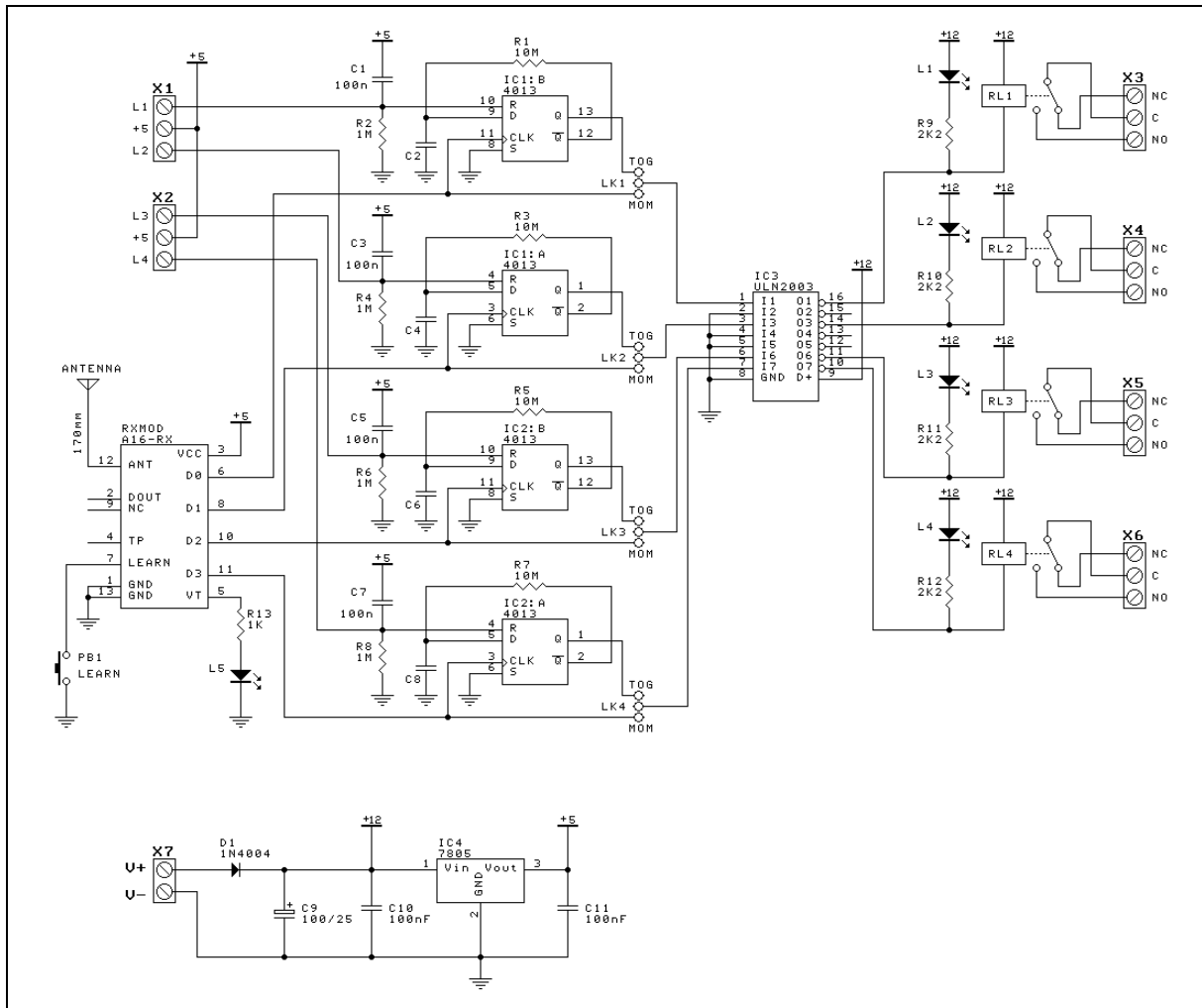

You may download the color photo from <http://www.quasarelectronics.com/jpg/3180v3.jpg>

