

QUASAR CODE 3171 - 250mW POWER AMPLIFIER

This project is a simple 2-transistor VHF power amplifier, with about 16dB gain, and requires no tuning or alignment procedures. Wideband techniques have been used in the design and the circuit is equipped with a "low-pass" filter to ensure good output spectral purity. The project has been designed for assembly on a single-sided printed circuit board. The circuit is specifically designed to amplify the output of 7mW to 10mW WBFM transmitters (wide band) to a final level of 250mW to 300mW, after the filter.

Circuit Description

The first stage (Q1) operates in Class-A. Although Class-A is the least efficient mode, it does offer more RF gain than other classes of bias, and Q1 is a low-level stage, when compared to the higher power Q2 stage. The output of this stage is around 70mW of RF power. The stage is untuned so that it gives a very broadband characteristic. The transistor is biased by means of R5, R6 and L6, and the residual (standing) DC current is set by R4. The input signal is coupled by C9 to the Base of the transistor.

Q2 is operated in Class-AB which leads to greater efficiency, but the RF gain is only about 8dB, but it amplifies the output of Q1 to typically 250mW. Q2 is biased by means of R3, R2 and L4. The input signal from Q1 is coupled to the Base of Q2 via C7.

The voltage regulator Q3 (78L08) is used to regulate the supply voltage to Q1 and the bias voltages to both Q1 and Q2 so that the output RF power is relatively constant, even with large variations of supply voltage. Q3 also removes supply ripple as well as providing power for an FM transmitter like Kit 3018 wireless microphone with the required DC 8v power.

The output of the amplifier is filtered with a low-pass filter to reduce the output spurious and harmonic content. The output filter consists of C3, C4, L1 and L2.

Assembly

No static sensitive components are used in the design of this project, so almost any component assembly order can be used. A good recommendation would be to fit all resistors first. All except one resistors are mounted horizontally on the board and have the lowest profile.

The next stage should include the ferrite bead inductors. Fit capacitors, then the filter inductors. Q1 and Q2 should really be fitted last, mainly because they are the largest components, but it is good practice to fit all active components last. Note that Q2 must be fitted with the heat sink supplied. Mount the transistor **a few mm above** the PCB surface.

Testing

Before applying power, it would be wise to re-check the component values. Check that there are no shorts or solder blobs bridging adjacent tracks or pads. If all is well then power can be applied for the first time.

When building power amplifiers, small mistakes can often lead to quite spectacular pyrotechnic displays. The

larger the amplifier then the more smoke potential the project can have. For this reason, all power amplifiers should be first powered with some form of current limiting power supply. If you do not have one, then wire a 12v 1A lamp bulb in series with the +12v supply line. If the lamp illuminates when the power is applied, then there is a fault, but the lamp will light, instead of doing costly damage to the amplifier.

Connect the (3018, or similar) 5mw - 10mW RF signal to the input of the amplifier and connect a suitable "dummy load" to the amplifier output. A dummy load burns up the RF power, instead of radiating it from an antenna. A suitable dummy load would be an RF wattmeter with an impedance of 50 Ohms. If an RF wattmeter is not available then a 6v 0.6W bicycle lamp is suitable. Switch on the 12v DC supply to the amplifier.

You should see some RF power out. If you are using the bicycle lamp dummy-load then it should glow dimly. If not, then check for wiring errors. Check that adjacent turns are not shorting in any of the inductors. But if all is well and you have some RF power, then remove the 12v lamp and apply the full 12v. You should now get somewhere between 200mW and 300mW of power (dummy load lamp at about half brilliance).

One final check: remove the RF source and check that the 250mW RF out disappears. Under certain conditions RF power amplifiers can "self-oscillate" (generate uncontrolled RF energy). Under this condition the output of such an amplifier will not be zero with no input. Self oscillation is caused by RF out fed back to the input, usually by magnetic or capacitive coupling, or via the power supply rail. Components with excessively long leads can also cause this effect. So, too, can certain wiring errors.

If the amplifier passes the self-oscillation test, then it is safe to connect an antenna. Listen to the signal. The sound quality of the transmitter should be the same, whether or not the amplifier is connected.

Conclusion

This amplifier is an excellent companion to the low-power FM microphones in the 7mW to 10mW range. In addition to exercising basic soldering skills, it also introduces the builder to some simple RF tests and basic techniques for higher power projects.

When you assembled the amplifier, you learned, or exercised, basic soldering skills. Testing the amplifier required some basic RF amplifier tests. These most basic tests should always be done when checking out any RF amplifier.

Support

If you need any further information about this product please email us:

mailto: support@quasarelectronics.com

QUASAR CODE 3171 - 250mW POWER AMPLIFIER

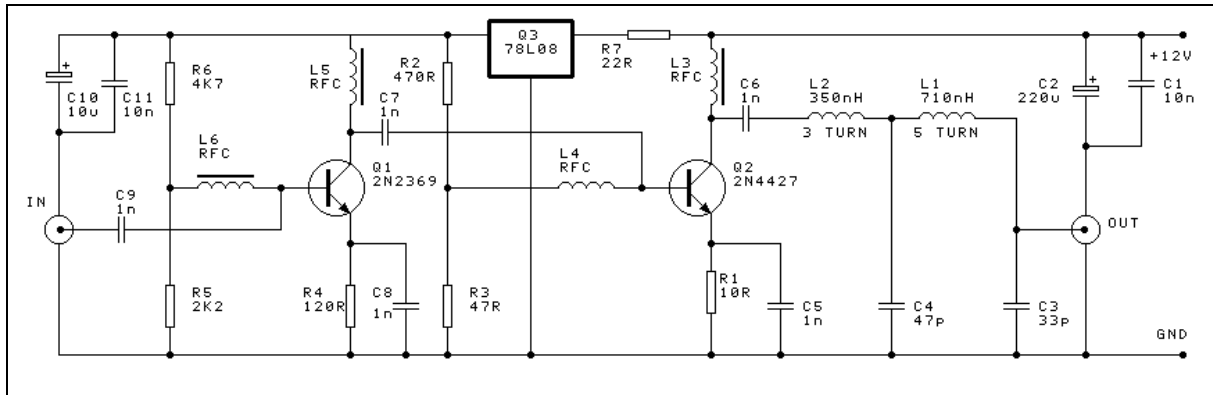

This photo shows how we tested Kit 3172 and 3171.

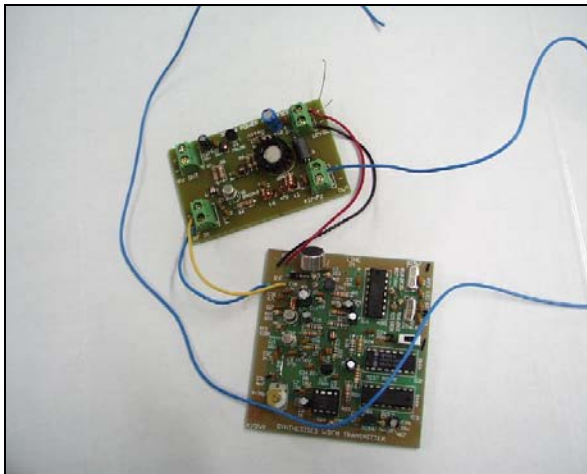

You may download the color photos from www.quasarelectronics.com/jpg/3171_3172.jpg

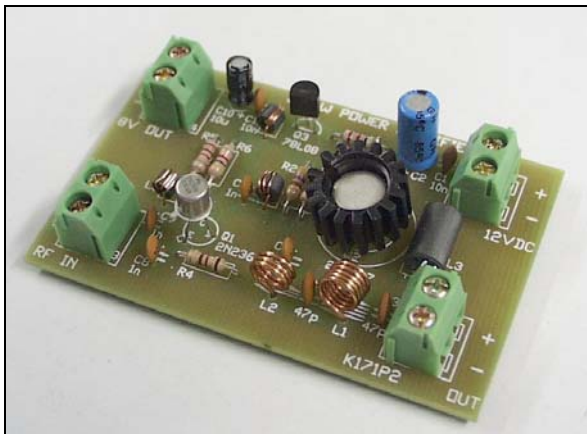

www.quasarelectronics.com/jpg/3171.jpg

COMPONENTS

Resistors 5%, 1/4W, carbon:

10R	R1	brown black black	1
22R	R7	red red black	1
47R	R3	yellow orange black	1
120R	R4	brown red brown	1
470R	R2	yellow violet brown	1
2K2	R5	red red red	1
4K7	R6	yellow violet red	1

2N2369	Q1	1
2N4427	Q2	1

Ceramic caps

33p	C3	1
47p	C4	1
1n	C5 C6 C7 C8 C9	5
10n	C1 C11	2

Ecaps:

220u/16V	C2	1
10u/25V	C10	1

78L08	Q3	1
RFC	L4 L5 L6	3
Ferrite	L3	1
3 turn coil	L2	1
5 turn coil	L1	1
2 pole terminal block		4
HS106	heatsink	1

3171 PCB		1
----------	--	---