

6 – 10 Watt Stereo Audio Amplifier (Code 3143)

Kit 3143 is a class AB stereo audio power amplifier designed for quality hi-fi applications using a TDA2005 module. It is easy to construct and has a minimum of external components. The module has output current protection and thermal protection. This is the data book circuit which produces an excellent sound. The supply voltage required for this kit is 8 - 18V DC at 1 to 2 Amps.

Maximum output power will only be obtained with a power supply of at least 2A at 15V DC, and using 2 Ohm speakers (or 2 by 4 Ohm speakers in parallel). However approximately 4W per channel can be obtained with only a 15V DC, 1A supply into 4 ohm loads.

The power supply should be well filtered to reduce mains hum, the on board capacitors alone are not adequate for this purpose but are necessary to ensure stability. Extra filtering is unnecessary if operating from a battery.

Construction.

Follow the printed circuit overlay with reference to the circuit diagram where necessary. Add the lowest height components to the board first, starting with the resistors. Be careful to get the electrolytic capacitors in the correct way around and all parts in their correct positions. Be careful when soldering the IC not to use excessive heat. Use some heat sink compound between the heat sink & the IC.

Also note if you intend to drive it very hard, it may require a bigger heatsink. The supplied heatsink is quite adequate for normal use. No damage will result, but the thermal protection circuit may limit the power output. Use shielded signal wire for the input connections, and at least 16/0.2 hook up wire for DC input and speaker outputs. Try to keep lead lengths as short as possible.

It is recommended that you place a solder lug (supplied) between the heatsink bolt head and front of the IC mounting tab. (NOT between the IC and heatsink) Connect the power supply earth to this lug. This reduces earth currents on the PC board, and lowers the distortion figures by a worthwhile amount. The circuit will, however, perform adequately without it.

Operation.

The circuit is straight forward. Most of the circuitry is contained within the amplifier module. C1 & C2 are input coupling capacitors and block DC, as do C10 & C11 which are the output coupling capacitors, and C7 & C9 which block DC from the feed back loop to the differential inputs. R3/R5 (and R4/R6) set the level of feed back. C10/R7 (and C11/R8) provide a high frequency load for stability where loudspeaker inductive reactance may become excessive. C4 and C5 provide power supply decoupling or filtering.

The gain is equal to $1 + (R3/R5) = 37$, or 31dB, minus any input attenuation. The gain may be increased by reducing the feedback resistors R5 and R6. A value of 22 ohms would provide a gain of approximately 35 dB. If you need much more than 40 dB gain, it would be better to use a preamplifier.

The maximum supply voltage for this Kit is 18V. Check the power supply voltage and polarity before connecting to the board. We found no trouble in getting this kit to work. If yours does not work, first check all external wiring, make sure there are no shorts, then check all the component positions and orientation. Also check all solder joints and make sure there are no dry joints or solder bridges.

You may download the full data sheet for the TDA2005 from my website :

www.quasarelectronics.com/software.htm

6 – 10 Watt Stereo Audio Amplifier (Code 3143)

Specifications :

D.C. Input :	8 – 18V at 1 – 2 A (15 - 30 VA minimum)
Power output :	> 8 W RMS / channel, 2 ohm load, 16V DC supply. > 6W RMS / channel, 4 ohm load, 16V DC supply. > 4W RMS / channel, 4 ohm load 12V DC supply.
THD	< 0.1% @ 1W, 4ohms.
S/N ratio :	> 80 dBA.
Frequency response :	~ 15 Hz to 50 kHz, -3 dB
Gain :	~ 30 dB maximum.
Input level :	~ 150 mV for full output

Components

Resistors :		Total
1 ohm, brown black gold	R7, R8	2
33 ohm, orange orange black	R5, R6	2
1k ohm, brown black red	R1, R9	2
1k2 ohm, brown red red	R3, R4	2
120k ohm, brown red yellow	R2	1
Capacitors :		
2u2 50V	C1 C2	2
10uF 25V	C3	1
100uF 25V	C5, C6, C8	3
220uF 25V	C7, C9	2
2200uF 16V	C12, C13	2
100 nF monoblock	C4	1
100 nF mylar	C10, C11	2
Kit 3143 Printed Circuit Board		1
TDA2005 amplifier module		1
Heat sink, HS215		1
Nut & bolt set for HS		1
10 k ohm dual gang log pot		1
3 pole terminal block		2
Solder lug		1

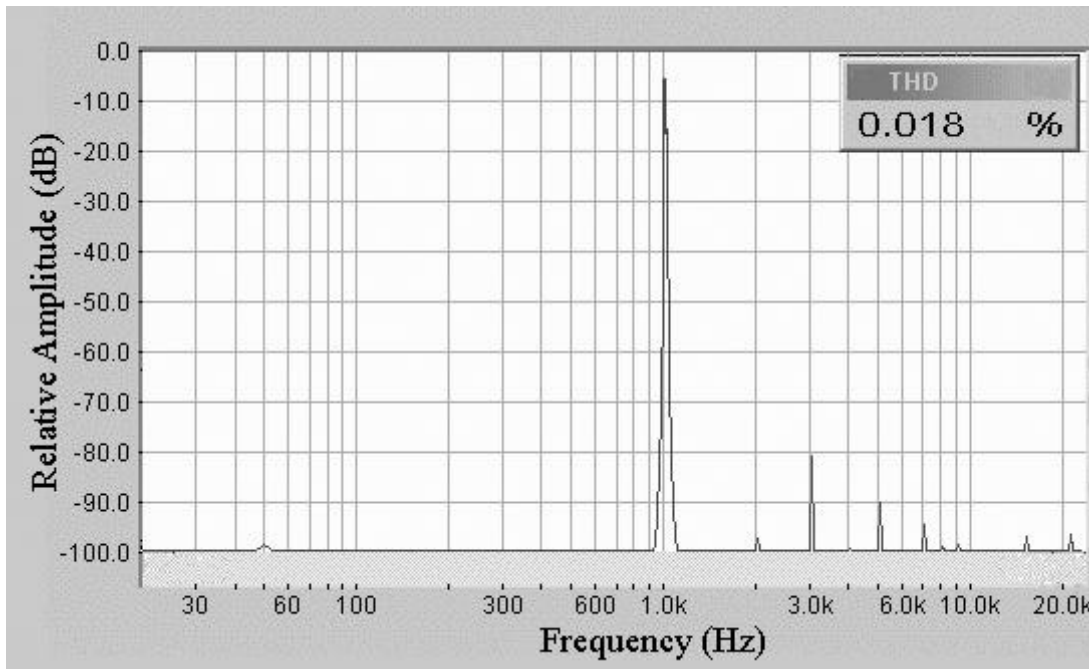

**Harmonic Distortion @ 1W RMS Output, 4 ohm load
1 kHz input and 15V DC supply**

6 – 10 Watt Stereo Audio Amplifier (Code 3143)

Circuit Diagram

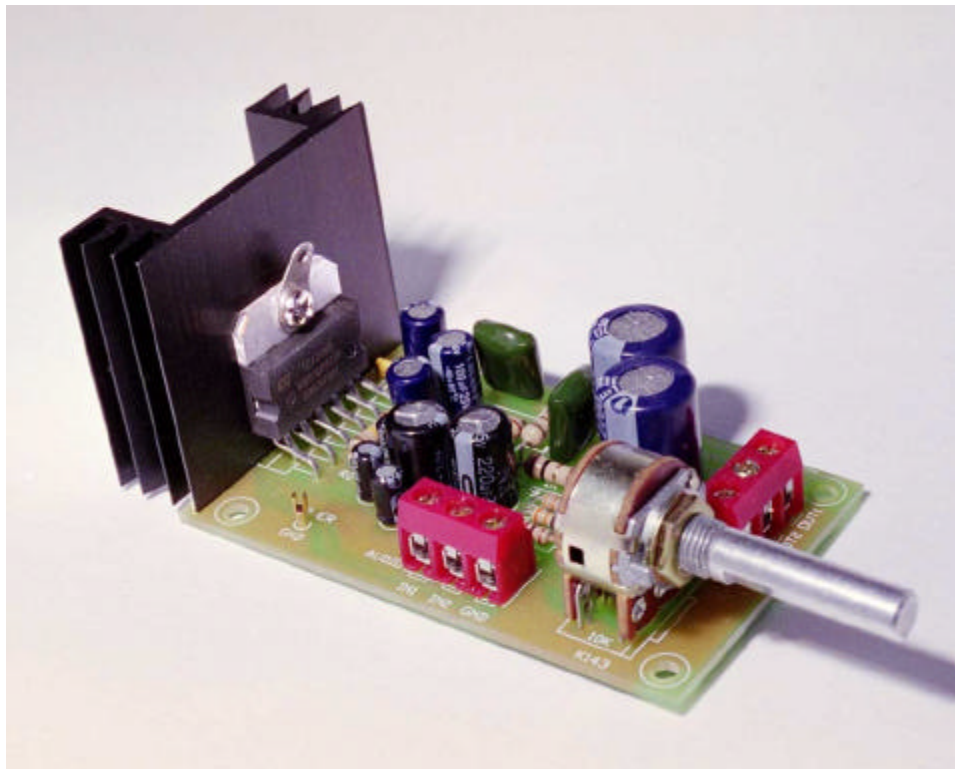
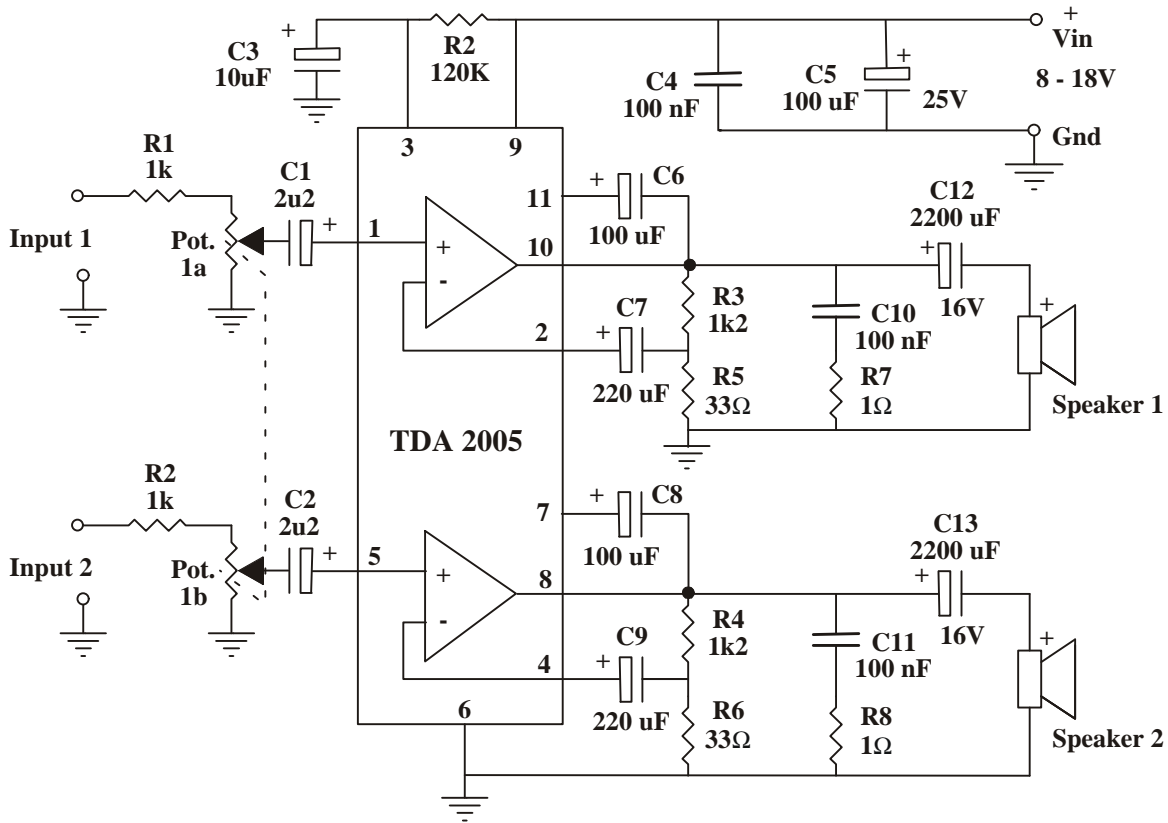

Photo showing power supply ground tag mounted on the I.C.