

QUASAR PROJECT # 3108U - Dual 3108 Upgrade Kit

This kit is an upgrade to allow 2 x 3108 kits to be connected together to provide 16 relay outputs and 6 opto-isolated inputs.

Kit 3108 has proved to be very popular. With 8 relay outputs and 4 opto-isolated inputs it can be used in a variety of applications in industry and around the home. However, a number of users wanted more inputs and outputs. They wanted to know if it was possible to hook up two 3108 kits to the one serial port. This was not possible for two reasons:

1. RS232 serial ports are only designed to have one device at a time connected to them. While it is possible for the PC to send data to multiple kits it is not possible for those kits to send data back. In the first case you would have one output driving many inputs – OK. In the second case you would have multiple outputs connected together trying to drive a single input – not possible.
2. Even if the above was possible, how would each kit know that the command it received was intended for it and not the other kit? Each kit would need a unique ‘address’ and there was no way to do this without redesigning the whole kit.

To overcome these problems the two kits are connected together via a ‘data link’ in a ‘master/slave’ setup. Only one kit is connected to the PC – this becomes the master.

Input 4 of each kit is used for the data link, which means each kit now has only 3 opto-isolated inputs instead of 4.

The master kit contains relays 1 to 8 and inputs 1 to 3. The slave kit contains relays 9 to 16 and inputs 4 to 6. When the master receives a relay or input number that belongs to the slave kit it simply sends the command on to the slave kit for processing.

CONSTRUCTION DETAILS

There are **FOUR** things to do with the upgrade kit and two assembled 3108s:

1. replace the existing firmware in 3108 with the two supplied, identical 3108dual firmware chips.
2. remove the front and rear panels of each 3108. You will have to unsolder and remove the LED bezels and reset switch. Add the Master panel and Relays 1-8 to one 3108, and the Slave panels with Relays 9-16 to the other.
3. Remove IC7, 4N25 from both 3108s. Insert two wire links either soldered on the bottom of the PCB underneath the IC7 socket or jumpered as shown:
 - Pin 1 to 5
 - Pin 2 to 4
4. The two 3108 kits need to be connected together via a data link. The data link uses Input 4 of each original kit. Use the short length 2-wire cable supplied to connect

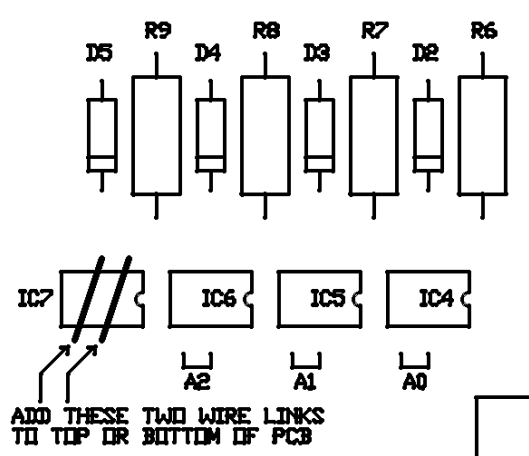
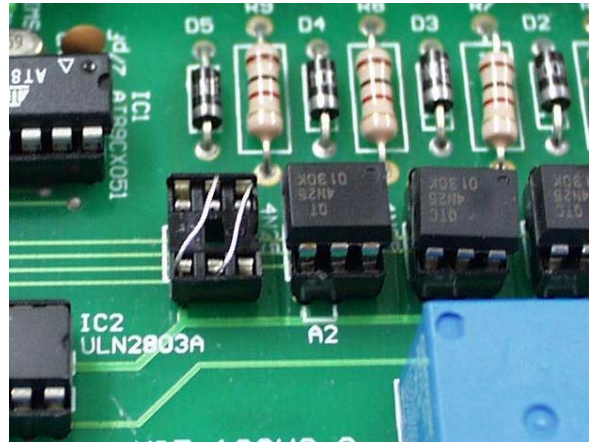

input 4 of each kit together, with the ‘+’ terminals connected to each other and the ‘-’ terminals connected to each other. Connect using the 2-pole screw terminal plugs supplied with each 3108 kit.

Longer wire lengths are possible between the two kits. However the data link uses TTL level pulses which will be affected by long wire lengths. Anything over 1 metre (36 inches) may cause problems. Try it and see!

Only **one** of the kits connects to the PC via the serial port. This will be the **Master** unit. It doesn’t matter which kit you connect to the PC. However, for ease of use, the front and rear panels are numbered differently for the master and slave so it makes sense to connect the kit labeled ‘Master’ to the PC serial port.

COMMANDS

The commands are the same as those in the original 3108 kit. There are **no new** commands. The only thing that has changed is the syntax of each ‘relay’ command because we are dealing with 16 relays instead of 8. Relay numbers now require two digits instead of one, including a leading zero if required.

A set of simple text commands is used to control the relays, return their status or read the inputs. Each command consists of a string of ASCII characters followed by carriage return (Enter ↵).

The ‘#’ character is output as a prompt to indicate the kit is waiting for a command. Each character received is

QUASAR PROJECT # 3108U - Dual 3108 Upgrade Kit

echoed back. On completion of each command, good or bad, a carriage return/line feed combination is output followed by the '#' prompt. If the command or parameter is invalid, the command is ignored and a '?' is output before the next '#' prompt.

Note:

- Commands are not processed until the carriage return character is received.
- Commands can be in upper or lower case.
- Relays are numbered 01 to 16. Relay number '00' (zero) indicates ALL relays.
- Inputs are numbered 1 to 6. Input number '0' (zero) indicates ALL inputs.

Where a hex byte or word is used, each bit represents its corresponding relay or input. Bit 0 indicates relay or input 1, bit 1 indicates relay or input 2, etc.

If the data link between kits is broken (or the slave kit not working) an following error message will be returned.

"Timeout error: Check connection to other kit"

This will only happen with commands that return the status of a relay or input in the slave unit ie. S00, S09-16 or I0, I4-6.

Nxx – Turn a relay ON (where xx = relay number)

Eg. N03 - turn on relay 3
N10 – turn on relay 10
N00 - turn on ALL relays

Fxx – Turn a relay OFF (where xx = relay number)

Eg. F03 – turn off relay 3
F10 – turn off relay 10
F00 – turn off ALL relays

Txx – TOGGLE a relay on/off (where xx = relay number)

Changes the state of a relay (ON to OFF, OFF to ON)

Eg. T03 – toggle relay 3
T10 – toggle relay 10
T00 – toggle ALL relays

Rhhhh – Set ALL relays directly

"hhhh" is a 16-bit hex word. Each bit within the word indicates whether the corresponding relay is operated or not. If the bit is '1' then the relay is operated, if the bit is '0' then the relay is released. Bit 0 represents relay 1, bit 1 is relay 2, bit 15 is relay 16.

Eg. R5555 – relays 1,3,5,7,9,11,13,15 ON, all others OFF
R0F0F – relays 1-4, 9-12 ON, all others OFF

Sxx – relay STATUS (where xx = relay number)

A '0' (zero) is returned if the relay is released, '1' if operated.

The command "S00" returns the status of ALL relays. A 16-bit hex word is returned. Each bit within the word indicates the status of the corresponding relay.

Eg. S03 – returns the status of relay 3
S10 – returns status of relay 10
S00 – returns the status of ALL relays

Ix – INPUT status (where x = input number)

A '1' is returned if the input is active or enabled, '0' otherwise.

The command "I0" returns the status of ALL inputs. An 8-bit hex byte is returned. Bits 0-2 indicate the status of inputs 1-3. Bits 4-6 return the status of inputs 4-6. Bits 3 and 7 are unused and are set to '0'.

Eg. I1 – returns the status of input 1
I4 – returns the status of input 4
I0 – returns the status of ALL inputs

A special command, '?', will print the software revision date.

WINDOWS SOFTWARE

Download the Windows software from
<http://www.quasarelectronics.com/zip/3108dual.zip>

IF IT DOES NOT WORK

Refer to the original 3108 documentation.

If the master link seems to be working but not the slave then check the data link between them. Does the '+' terminal connect to '+' and '-' to '-' ?

PART LIST – DUAL 3108

AT89C2051 uC.....	for IC1.....	2
pre-programmed, identical firmware chips		
Front & rear panels, "Master".....		1 set
Front & rear panels, "Slave".....		1 set
2-wire cable.....		12"

GETTING HELP

You can email us if you have any technical queries about this kit:

mailto: support@quasarelectronics.com

For ordering information please visit
<http://www.quasarelectronics.com/3108u.htm>

You can view jpgs of the upgraded kit at

http://www.quasarelectronics.com/jpg/3108d_1.jpg
http://www.quasarelectronics.com/jpg/3108d_2.jpg
http://www.quasarelectronics.com/jpg/3108d_3.jpg