

QUASAR PROJECT # 3097 - 2W Amplifier Module

This is a very simple 2 watt mono amplifier module built around the National Semiconductor LM380 amplifier Integrated Circuit.

- The IC has a low component count
- No external heatsink is necessary
- It is short circuit and overload protected
- High gain

Specifications :

D.C. input :	10 - 20 V at 300 mA.
Idle current	< 25 mA, 7-15 mA typical.
Power output	> 2 Watt max. (4-8 ohms, 20V) > 1 Watt max. (4-8 ohms, 12V) > 0.5 Watt RMS continuous
Freq. Resp.	< 20 Hz to >100 kHz – 3dB
Distortion	< 0.2 % @ 1W.
S/N ratio	> 85 dB
Gain	~ 50 x or 34 dB maximum.
Input level	< 100 mV for full output.
Input Z	~ 10 k ohm.

Assembly Instructions :

Assembly is very straight forward. Solder the integrated circuit in place first before installing the rest of the components. Make sure you get the I.C. and the electrolytic capacitors the correct way around. The IC has a notch at one end, which is marked on the PC board overlay. The electrolytic capacitors are polarized, they have a + or - marked on them and they must be inserted correctly into the PCB. Leave the potentiometer until last.

Check the polarity before connecting the battery or power supply. A DC supply of 10 to 20V at 300 mA or greater is required. A plug-pack supply will be suitable, but may require extra filtering if noise is a problem. If it does not work, recheck all component positions and polarity. Check all solder joints, and all external wiring. The IC itself is quite robust, and there is very little else to go wrong. Poor solder joints

are the main cause of problems. A visual inspection using a magnifier will find most “dry joints” or “solder bridges”.

Remember when testing, it will not produce full output for more than a short duration because of limited heat dissipation. For normal music applications you should have no problems as long as the output is kept from severe clipping. This will result in quite audible distortion and should be avoided. It will not produce full output before clipping with a DC input of less than 15V for 8 ohm loads.

If you do require a sustained output of more than ½ watt, you will need to add a heatsink as described in the National data sheet available on our web site.

Circuit Description :

There are only a few external components. C1 is the input coupling capacitor, which blocks any DC that might be present at the input. C2 is the output coupling capacitor which is required to block the DC level (half supply voltage) that is present at the amplifier output, from reaching the speaker. C5 and C6 provide power supply decoupling or filtering, and C4 provides an internal supply bypass for extra supply decoupling.

R2 and C3 form a zobel network for high frequency load stability. The pot provides an adjustable input level, this can be used as a volume control. D1 is not strictly necessary and is only to prevent damage if the power supply is connected incorrectly.

The National data sheet contains additional information about the LM380. You may download it from the 3097 product page on our website at :

<http://www.quasarelectronics.com/3097.htm>

QUASAR PROJECT # 3097 - 2W Amplifier Module

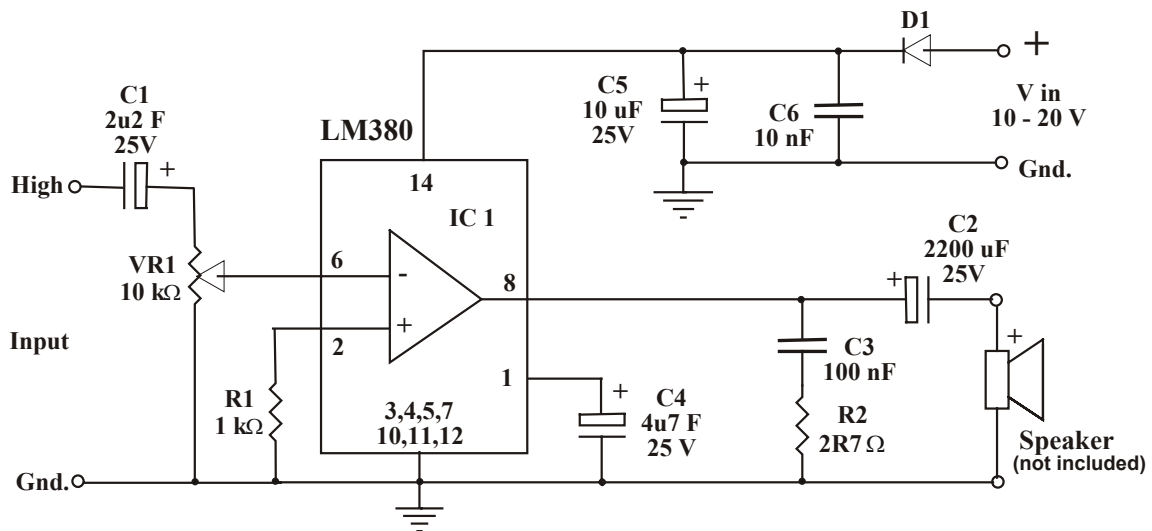

Components :

C1 :	2.2 uF electrolytic capacitor	1
C2 :	2200 uF electrolytic capacitor	1
C3 :	100 nF polyester capacitor	1
C4 :	4.7 uF electrolytic capacitor	1
C5 :	10 uF electrolytic capacitor	1
C6 :	10 nF polyester capacitor	1
R1 :	1K ohm resistor (brown, black, red)	1
R2 :	2R7 ohm resistor (red, violet, gold)	1
D1 :	IN4004 diode	1
VR1 :	10K ohm log potentiometer	1
IC1 :	LM380 Integrated Circuit	1
	3097 Printed Circuit Board	1
	PCB Pins	6

QUASAR PROJECT # 3097 - 4W Amplifier Module

Harmonic Distortion at 1kHz, 1Watt output.

