

QUASAR PROJECT KIT 3088 - 10W + 10W STEREO AMPLIFIER

Kit 3088 is a class AB stereo audio power amplifier designed for quality hi-fi applications using a TDA2009A module. It is easy to construct and has a minimum of external components. The module has output current protection and thermal protection. This is the data book circuit which gives an excellent sound. The supply voltage required for this kit is 8 - 24V DC at 1 to 2 Amps. Maximum output power will only be obtained with a power supply of at least 20V and greater than 1.5 A, and using 4 ohm speakers.

The power supply should be well filtered to reduce mains hum, the on board capacitors alone are not adequate for this purpose but are necessary to ensure stability. Extra filtering is unnecessary if operating from a battery.

Specifications :

D.C. Input :	8 – 24V at 1 – 2 A
Power output :	10W / channel, 4 ohm load 24V DC supply. 6W / channel, 8 ohm load 24V DC supply. 4W / channel, 4 ohm load 12V DC supply.
Gain :	~ 27 dB or 36 dB optional
Input level :	~ 300 mV, G = 27 dB ~ 100 mV, G = 36 dB
S/N ratio :	> 85 dB (G = 27 dB) > 75 dB (G = 36 dB)
THD :	< 0.2 % at 5W
Freq. response :	<20 Hz to >50 kHz –3 dB ~ 10 Hz to 300 kHz G=27dB

Construction.

First decide how much gain you require. For general audio applications, R2, R4 should be 56 ohm, giving a gain of 27 dB. This will provide lower noise and distortion when driven by most CD/MP3/tape players etc. Follow the printed circuit overlay with reference to the circuit diagram where necessary. Add the lowest height components to the board first, starting with the resistors. Be careful to get the electrolytic capacitors in the correct way around and all parts in their correct positions.

Be careful when soldering the IC not to use excessive heat. Use some heat sink compound

between the heat sink & the IC. Also note if you intend to drive it very hard, it will require a bigger heatsink. Also make sure there is sufficient airflow to the heatsink if placed in a box. Alternatively a suitable aluminium case can make a good heatsink.

A useful modification is to place a solder lug between the IC metal tab and the heatsink bolthead. Connect the power supply earth to this lug instead of the board terminal. This removes the power supply ground current from the PC board, and reduces distortion figures. The amplifier will still work satisfactorily without this modification however.

Use shielded signal wire for the input connections, and at least 16/0.2 hook up wire for DC input and speaker outputs. Try to keep lead lengths as short as possible

Operation.

The circuit is very straight forward. Most of the circuitry is contained within the amplifier module. C1 & C2 are input coupling capacitors and block DC, as do C10 & C11 which are the output coupling capacitors, and C6 & C7 which block DC from the feed back loop. R1/R2 (and R3/R4) set the level of feed back.

The gain is equal to $1 + (R1/R2) = 68$ (37dB) for R2, R4 = 18 ohm, and 22 (27dB) for R2, R4 = 56 ohm. C8/R5 (and C9/R6) provide a high frequency load for stability where loudspeaker inductive reactance may become excessive. C4 and C5 provide power supply decoupling or filtering.

The absolute maximum supply voltage for this Kit is 28V. Check the power supply voltage and polarity before connecting to the board. We found no trouble in getting this kit to work. If yours does not work, first check all external wiring, make sure there are no shorts, then check all the component positions and orientation. Also check all solder joints and make sure there are no solder “bridges”.

You may download the full data sheet for the TDA2009A from our website :

<http://www.QuasarElectronics.com>

or from ST Microelectronics at : www.st.com

QUASAR PROJECT KIT 3088 - 10W + 10W STEREO AMPLIFIER

Circuit Diagram

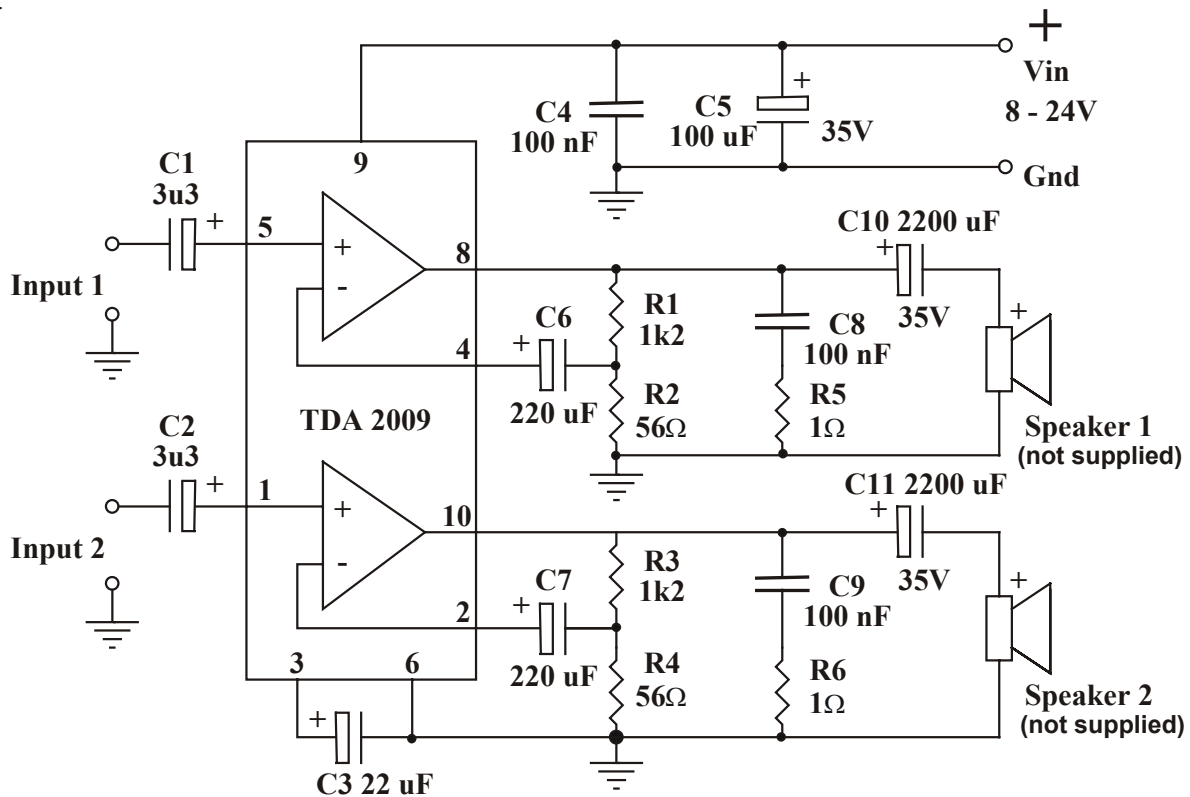

Components

Resistors : 1/2W, 5%.

R1 R3	1K2 (brown red red)	2
R5 R6	1 R (brown black gold)	2
R2 R4	18 R (brown grey black)	2
OR	56 R (green blue black)	2

Capacitors :

3u3 50V mini	C1 C2	2
22uF 16V	C3	1
100uF 35V	C5	1
220uF 10V	C6 C7	2
2200uF 35V	C10 C11	2
100nF 104 mylar	C4 C8 C9	3

TDA2009A amp module	1
3088 Printed Circuit Board	1
Heat sink HS215 or HS110	1
Nut & bolt set for HS	1
3mm Solder lug	1
2 pole terminal block	1
3 pole terminal block	2

QUASAR PROJECT KIT 3088 - 10W + 10W STEREO AMPLIFIER

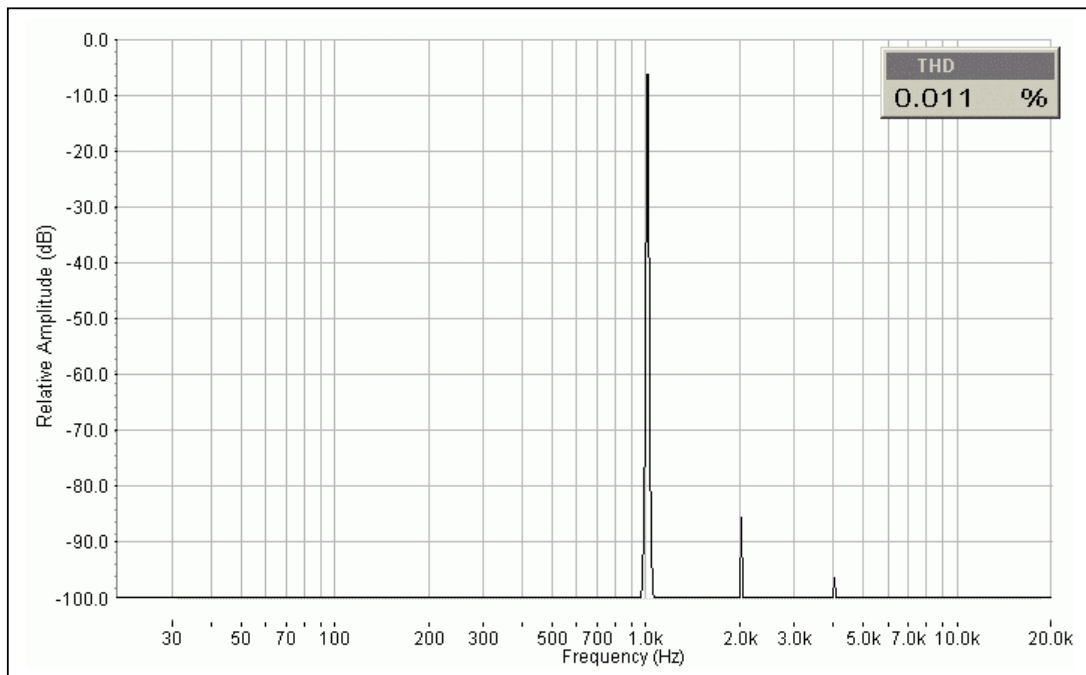

**Distortion @ 1W RMS Output
1 kHz input and 24V DC supply:**

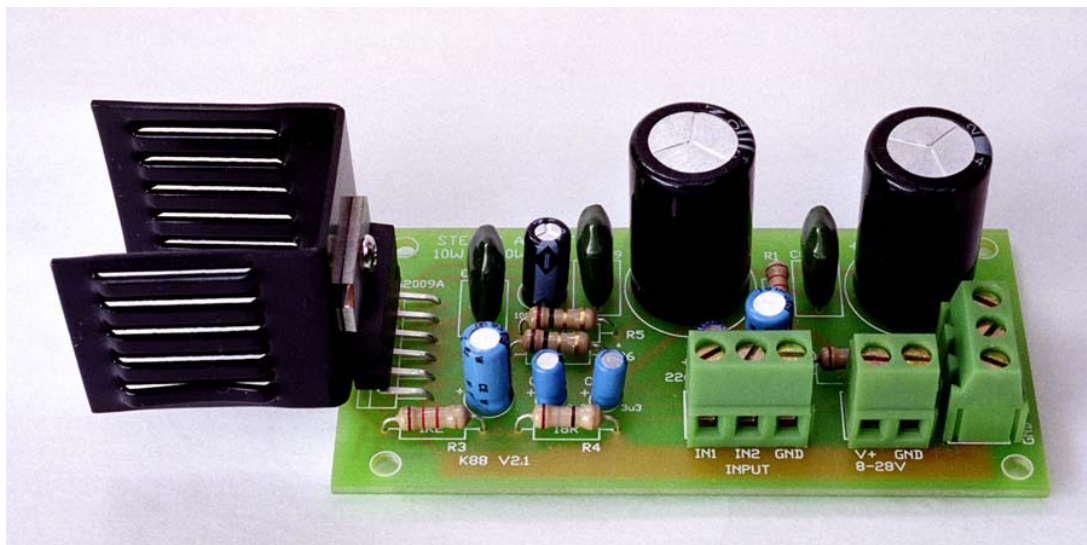

Photo of completed kit