

QUASAR PROJECT KIT # 3052M - 5 LED RANDOM/SEQUENCE FLASHER

This cmos VLSI single chip-on-board is designed for electronic toy and warning light applications. Five LED's flash on/off in a pseudo-random or sequential mode depending on whether a switch is open or connected high. Continuous flashing mode or toggle on/off is selectable by another switch. The flash rate is controlled by a trimpot. Typical standby current is less than 1uA with both switches unconnected. 2.0V to 3.6V operation. Operating current 10 - 16mA.

Construction. A mother board is supplied with the kit to make assembly as easy as possible. Solder the COB PCB into the slot provided at each of the 14 pins. Be careful you do not short out two adjacent pins with solder. The only critical point to watch is to get the height of all the LED's exactly what you want. We suggest you use some cardboard & sticky tape to fix all the LED's into position before you solder their legs.

Make sure the flat on each LED body (cathode) corresponds to the flat shown on the overlay. All 5 LED's face the same way. Connect the 3V battery snap and some batteries. The flashing frequency can be changed by the trimpot resistor between pins 5 & 6.

The flashing sequence may be continuous or toggle-on/toggle-off according to the position of switch SEL1 and the jumper connection.

Continuous. Switch to CONTinuous & place the jumper in position. The second switch determines whether the flash pattern is sequential or pseudo-random.

Toggle On/Off. Switch to TOGGLE and remove the jumper. The flashing sequence is started by momentarily connecting pin 10 to ground. That is, by shorting across the jumper connection. Then it is stopped by a second shorting of the jumper connection. If SEL1 is connected to ground permanently then the flashing sequence is continuous.

PINOUT

Bonded on a 29mm x 16mm single sided PCB. Not all die pads are brought out.

PCB Position	Pin Function
1	LED4
2	LED3
3	LED2
4	LED1
5	Oscillator 1
6	Oscillator 2
7	+3V, VDD
8	SEL2
9	SEL1
10	on/off
11, 12	N/C
13	Ground, VSS
14	LED5

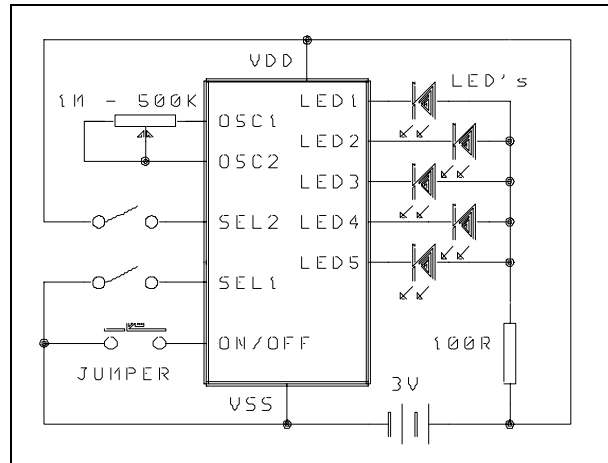

KIT COMPONENTS

Motherboard	1
3V battery snap	1
Koa trimpot 500K - 1M	1
100R resistor brown black brown	1
SPDT switch	2
5mm ultra bright LED	5
3052 COB PCB	1
2-pin post header	1
Jumper	1

