

Quasar Kit 3047 - 6-10 Watt Mono Audio Power Amplifier

Kit 3047 is a class AB audio power amplifier using a TDA2002 or TDA2003 module. These are replacements for the original LM383 which is no longer available. It is easy to construct and has a minimum of external components. The module has both short circuit protection and thermal protection. It can drive loads as low as 1.6 ohm and is capable of delivering over 10 watts from a 16 V supply. The power supply required for this kit is 8 - 18V DC at 1 Amp or more.

Maximum output power will only be obtained with a power supply of greater than 1A at 16V DC, and using 2 ohm speakers (or 2 by 4 ohm speakers in parallel). However approximately 4W RMS can be obtained with a 12V DC, 1A supply into a 4 ohm load.

The power supply should be well filtered to reduce mains hum, the on board capacitors alone are not adequate for this purpose but are necessary to ensure stability. Extra filtering is unnecessary if operating from a battery. If two boards are used for stereo, you will need to double the size of the power supply.

Construction.

Follow the printed circuit overlay with reference to the circuit diagram where necessary. Add the lowest height components to the board first, starting with the resistors. Be careful to get the electrolytic capacitors in the correct way around and all parts in their correct positions. Be careful when soldering the IC not to use excessive heat. Use some heat sink compound between the heat sink & the IC. Be careful not to put too much strain on the Heatsink as it is only supported by the IC pins.

It is recommended that you place a solder lug between the heatsink bolt head and front of the IC mounting tab. (NOT between the IC and heatsink) Connect the power supply earth to this lug. This reduces earth currents on the PC board, and lowers the distortion figures by a worthwhile amount. The circuit will perform adequately without this modification however.

Use shielded signal wire for the input connections, and at least 16/0.2 hook up wire for DC input and speaker outputs. Try to keep lead lengths as short as possible.

Operation.

The circuit is straight forward. Most of the circuitry is contained within the amplifier module. C1 is the input coupling capacitor and blocks DC, as does C3 which is the output coupling capacitor, and C2 which blocks DC from the feed back loop to the differential input. R2 and R3 set the level of feed back. C4 and R4 provide a high frequency load for stability where loudspeaker inductive reactance may become excessive. C5 and C6 provide power supply decoupling or filtering. We have increased C3 from 1000uF (1mF) to 2200uF so if you have a PCB marked 1mF then the 2200uF is OK.

The maximum supply voltage for this Kit is 18V. Check the power supply voltage and polarity before connecting to the board. We found no trouble in getting this kit to work. If yours does not work, first check all external wiring, make sure there are no shorts, then check all the component positions and orientation. Also check all solder joints and make sure there are no dry joints or solder bridges.

You should have no problems with stability, however if you do, first make sure the power supply filtering and leads are adequate. If necessary you might connect an RC compensation network between IC pins 2 and 4 as in the data sheet. Values for Cx of 22 - 33 nF and for Rx of 39 - 47 ohms, should be satisfactory whilst still maintaining satisfactory high frequency response.

The gain is equal to $1 + (R2/R3) = 101$, or 40 dB, minus any input attenuation. You may reduce the overall gain by increasing the value of R3 if you are only able to use part of the potentiometer range as a volume control. For example, an R3 of 10 ohms will give a gain of 23 (27dB). You may need to recalculate the above value for Rx if necessary, so that $Rx = 20 \text{ times } R3$ (approx.)

You may download the full data sheet for the TDA2003 from my website :

<http://www.quasarelectronics.com/ds.htm>

Quasar Kit 3047 - 6-10 Watt Mono Audio Power Amplifier

Specifications :

D.C. Input : 8 – 18V, 10 – 20 VA min.
 Power output : > 10 W RMS, 2 ohm load,
 16V DC supply.
 > 6W RMS, 4 ohm load,
 16V DC supply.
 > 4W RMS, 4 ohm load,
 12V DC supply.
 THD : < 0.2% (1W, 4 ohm load)
 Gain : 40 dB maximum.
 S/N ratio : > 80 dBA. (G = 20 dB)
 > 60 dBA (G = 40 dB)
 Frequency response : < 20 Hz to > 40 kHz
 (-3dB, 4 ohm load)
 Input level : < 100 mV for full output
 (G = 40 dB)
 < 1V for full output
 (G = 20 dB)

Components

Resistors :		Total
10 k ohm log. potentiometer	R1	1
220 ohm, red red brown	R2	1
2R2 ohm, red red gold	R3	1
1 ohm, brown black gold	R4	1
Capacitors :		
10uF 50V ecap	C1	1
470uF 16V ecap	C2	1
2200uF 25V ecap	C3	1
100 nF mylar	C4	1
100 nF monoblock	C5	1
100uF 25V ecap	C6	1
3047 Printed Circuit Board		1
TDA2002/3 amplifier module		1
Heat sink, HS215		1
Nut & bolt set for HS		1
Solder lug – 3mm		1
2 pole terminal block		3

Harmonic Distortion @ 1W RMS Output, 4 ohm load 1 kHz input and 12V DC supply

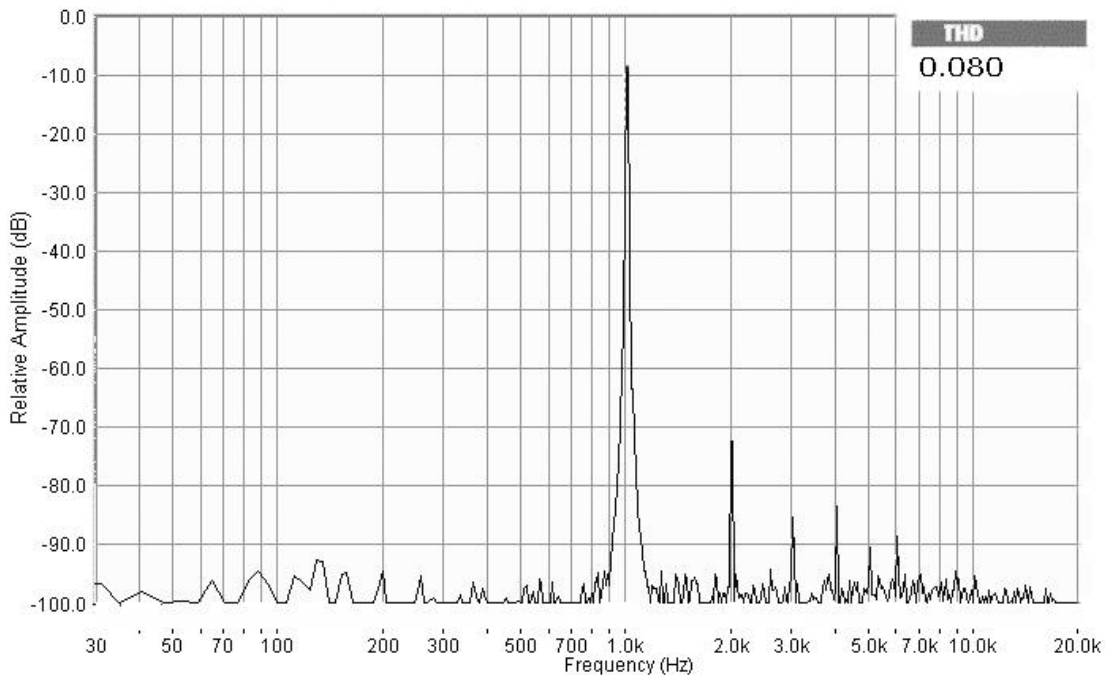

Quasar Kit 3047 - 6-10 Watt Mono Audio Power Amplifier

Circuit Diagram

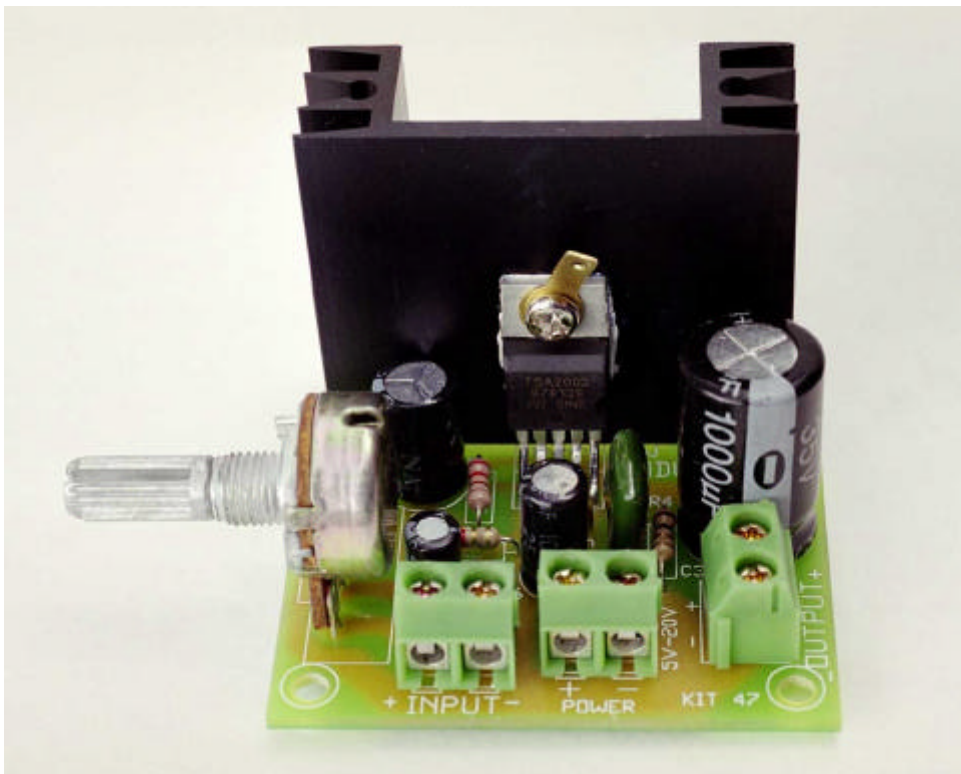
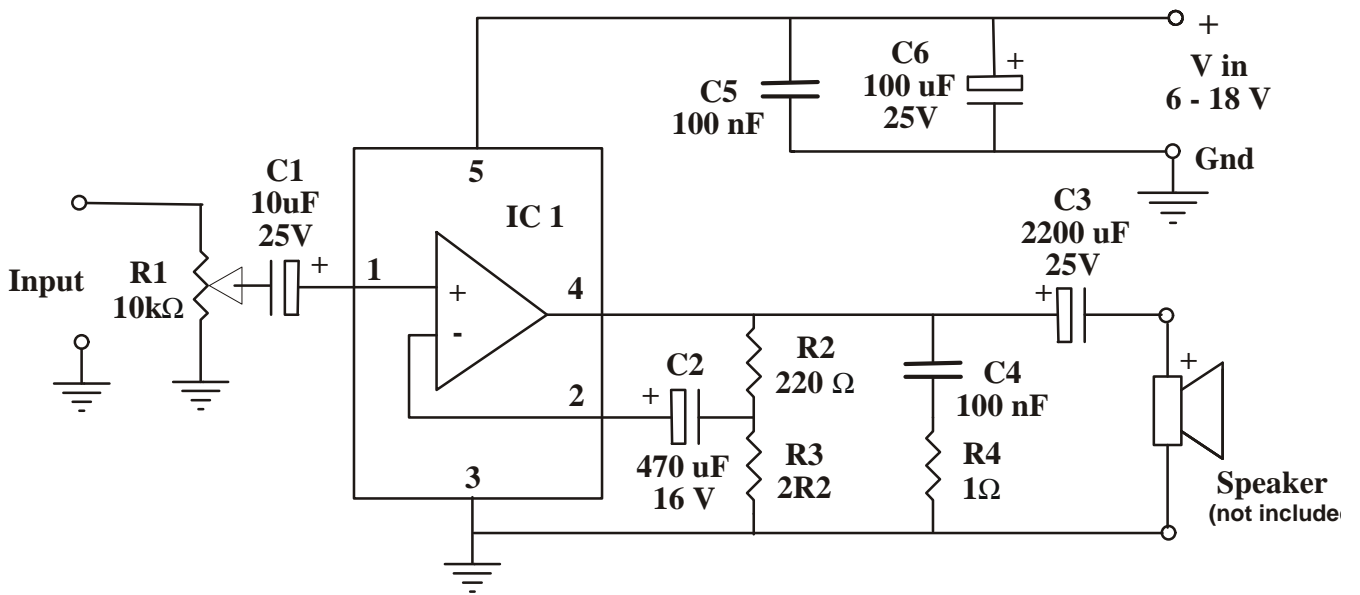

Photo showing optional power supply ground tag mounted on the I.C.
(Note output capacitor is now 2200 µF)