

# QUASAR KIT # 3045 - TWIN 120Vac/24Vdc, 1A RELAY BOARD

In developing our range of kits we found many applications where we needed a quick and easy method of connecting a relay to a particular piece of equipment. So we produced this series of PCB mounted relays boards (kits 3043, 3044 and 3045). See our website at [www.QuasarElectronics.com](http://www.QuasarElectronics.com) for details of these and other kits.

ITEM	DESCRIPTION	QTY
D1, 2	1N4004 Diode	2
RL1, 2	12V/1A Relay	2
TB1, 2	5 Pole Terminal Block	2
PCB	Quasar Kit 3045	1

We use a pair of high quality 12V relays (coil resistance 700 Ohm). The diode D1 provides a discharge path for the back EMF generated by the collapsing magnetic field of the relay coil when the power is removed. Assembly is very easy. Just make sure you get the diodes round the right way. The bar on the diode should match the bar on the overlay.

The **maximum output load is 1 Amp @ 110Vac/24Vdc** (even though the relay supplied might exceed this rating the PCB tracks are the limiting factor).

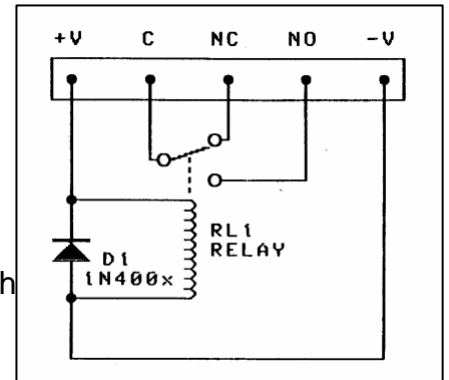

## General Guidelines for Electronic Kits and Assembled Modules

Thank you for choosing one of our products. Please take some time to carefully read the important information below concerning use of this product. The assembly and operating instructions are on the following pages.



### WEEE Directive (Waste Electrical and Electronic Equipment)

#### Notice To All European Union Citizens. Important environmental information about this product.

The crossed out wheeled bin symbol on this product, package or documentation indicates that disposal of this product after its lifecycle could harm the environment. Do not dispose of this product (or batteries if used) as unsorted municipal waste. It should be disposed by a specialized company for recycling. The unit should be returned to your distributor or to a local recycling service. Please respect the local environmental rules. If in doubt contact your local authorities about waste disposal rules.

### Safety: General rules concerning safe use of our Kits or Modules.

To ensure your safety, please observe these safety measures. In no way are these complete. As safety requirements vary, please check with your local authorities, in order to comply with local requirements. If in doubt, seek the help of a qualified person.

**Battery or wall-adaptor operated devices are safe devices. They do not require special attention unless mains voltage is connected to an output e.g. a relay.**



To ensure electrical safety, and also protection from fire or personal injury, make sure your mains operated equipment complies with these safety hints:

- Use a suitable plastic enclosure. If a metal enclosure is used, make sure it is properly earthed.
- Use a power switch if the device consumes more than 10W. Use a double pole switch for mains operated, transformer-less kits.
- Mount a fuse in series with the mains switch. Use a slow blow (T) 50mA fuse for transformers up to 10W and a 100mA fuse for transformers up to 20W.
- Use a mains input connector, or a robust power cord with a clamp. Internal wiring carrying mains voltages must have a minimum cross-sectional area of 0.5mm<sup>2</sup>.

If supplied, attach the power rating label near the power cord of the device and fill-out the mains voltage, frequency, power consumption and fuse values.

### Troubleshooting and Support

90% of non working kits are due to poor soldering.

We operate a Get-You-Going service for non-working kits but there is a charge based on the time and components needed to complete the repair. Quite often it is not economically viable for us to repair and it is cheaper to supply a new ready made product at full cost.

### Disclaimer

Quasar Electronics reserves the right to change product specifications or to discontinue products without notice. Quasar Electronics cannot be held responsible for any loss or damage, direct or indirect, which might occur from the use of a product. Quasar Electronics Kits or Modules are intended for educational and demonstration purposes only. They are not intended for use in commercial applications. If they are used in such applications the purchaser assumes all responsibility for ensuring compliance with all local laws. In addition, they are not suitable for use as or as a part of life support systems, or systems that might create a hazardous situation of any kind.

# GENERAL RELAY INFORMATION

## Warning! Risk of Electric Shock!

This information concerns kits and modules with relay outputs. TO USE THE RELAY OUTPUTS SAFELY YOU MUST OBSERVE THE MAXIMUM VOLTAGE AND CURRENT LIMITS QUOTED IN THE **PRODUCT DOCUMENTATION** (this is because the board design may not be rated to switch the maximum voltage and current limits printed on the relay itself or specified in the relay manufacturer's data sheet).

Controlling mains equipment with relay outputs must be treated with extreme caution. Electric shocks can cause severe and permanent injury or even death. Construction, installation, testing and commissioning should only be attempted by suitably qualified persons, or under the supervision of a suitably qualified person. These products are not suitable for children. Before connecting mains powered equipment to the relay outputs please check with the relevant authorities in order to ensure compliance with all current safety regulations. Many areas of the assembly may operate at mains voltage. A suitable isolating enclosure must be used. Exposed screw terminal blocks on some products must be insulated to prevent contact with exposed metallic parts at mains potential. Connected equipment should be suitably fused.

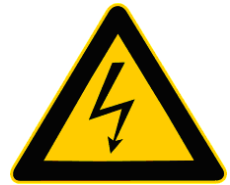

You will find relay outputs on many of the kits and modules that we sell. A relay is an electrically operated on/off switch. The voltage and current limits specified in the product documentation generally relate to resistive or light inductive loads.

## Relay Terminals

Most boards have SPDT (Single Pole Double Throw) style relays. These have three outputs:

**C** = Common

**NO** = Normally-Open contacts connect the circuit when the relay is activated; the circuit is disconnected when the relay is inactive. It is also called a Form A contact or "make" contact.

**NC** = Normally-Closed contacts disconnect the circuit when the relay is activated; the circuit is connected when the relay is inactive. It is also called a Form B contact or "break" contact.

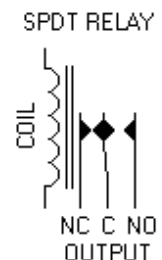

## Connecting the Device you want to Control

You must provide an external power source to the device you want to control. No voltage is present at the relay terminals (remember it is just a switch). The relay is normally connected in *series* with the positive (+) power wire of the device you want to control.

In this case, the positive wire from the power source should be connected to Common. Then either the NO or NC terminal (as appropriate for your purpose) is connected to the positive (+) wire going to the device you want to control. The negative (-) wire does not connect to the relay at all. It goes directly from the power source negative output to the device negative (-) terminal.

## Typical SPDT Relay Connection Diagrams

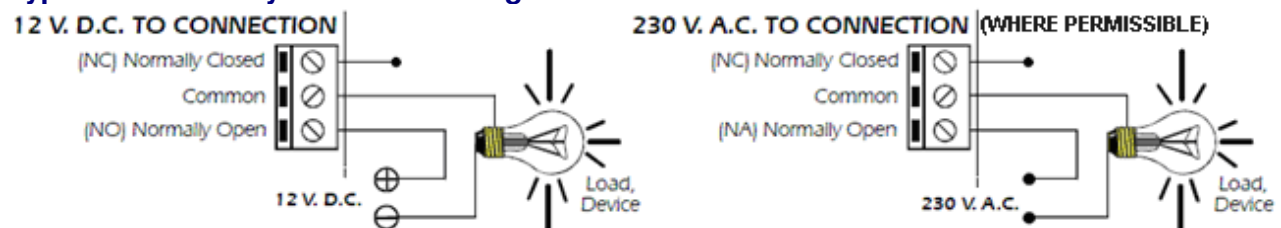

## Anti-Spark SPDT Relay Connection Diagram

Sometimes the connected equipment can cause arcing across the relay contacts. This must be corrected by installing a resistor and capacitor (not supplied) between the two contacts of the relay as shown below. Component values are for 230Vac mains.

