



Quasar Electronics Limited  
PO Box 6935  
BISHOP'S STORTFORD  
CM23 4WP, UNITED KINGDOM

TEL: +44 (0)8717 177 168  
FAX: +44 (0)8712 772 728  
E-mail: sales@QuasarElectronics.com  
Website: www.QuasarElectronics.com

## Electronic Kit / Module Available Using This Component!

Component Number: BA5406

Product Description: 3W Stereo Amplifier module with Heatsink

Quasar Order Code: 3090H

Product URL: <http://www.quasarelectronics.com/3090h.htm>

The **component PDF datasheet that follows** is brought to you by Quasar Electronics, the UK's number one specialist in electronic kits, electronic projects and electronic modules.

For details of products using this and other components please see our website at <http://www.QuasarElectronics.com> and use the SEARCH box to find items that incorporate the component in the design.

**Scroll down for the component Datasheet you want!**

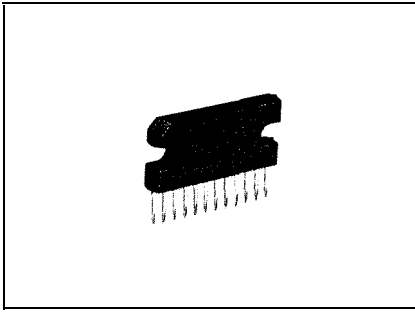

The BA5406 is a monolithic dual OTL power amplifier containing two sets of high-power AF power amplifiers. The device delivers 5 watts x 2 into 3Ω loads with a 12V supply, or 2.8 watts x 2 into 3Ω loads with a 9V supply. The BA5406 features minimal power-on pop noise and immunity to supply voltage drop. With its minimal RF radiation, the device is ideally suited for use in stereo radio cassette recorders.

**Features**

1. Minimal power-on pop noise.
2. Immunity to supply voltage drop (operates down to  $V_{CC}=4.5V$  typ.).
3. Excellent channel balance.
4. Low distortion (THD=0.3% at PO=0.5W).
5. 12-pin SIP package for mounting ease and saved space on a PC board.
6. Ripple filter input (pin 6) can also be used as a muting control input.
7. Symmetrical pin configuration facilitates art work.
8. Low thermal resistance of the package makes heat-sink design easy.
9. Built-in high-frequency phase compensation capacitor.
10. Minimal RF radiation allows for free system layout.

**Applications**

Stereo radio cassette recorders  
Desktop stereo systems  
Multiplexed audio subchannels for TV sets

**Dimensions (Unit: mm)**

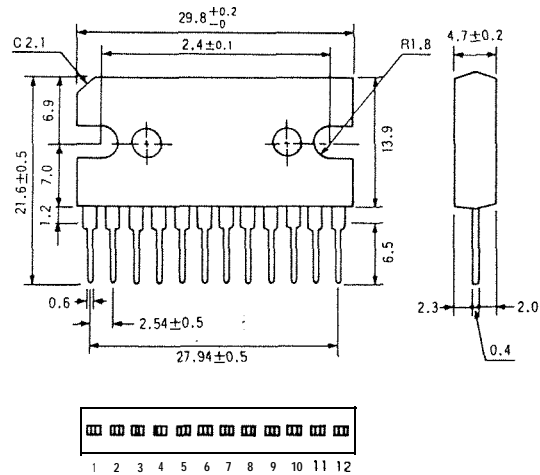

Fig. 1

**Block Diagram**

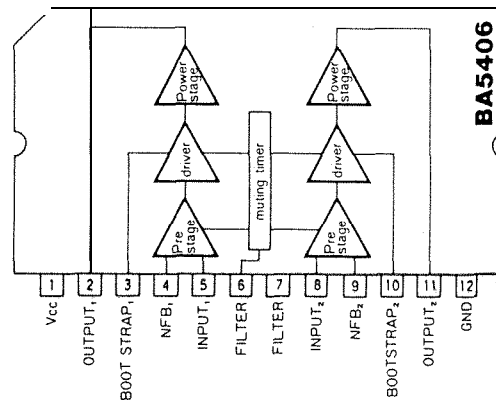

Fig. 2

**Internal Equivalent Circuit**

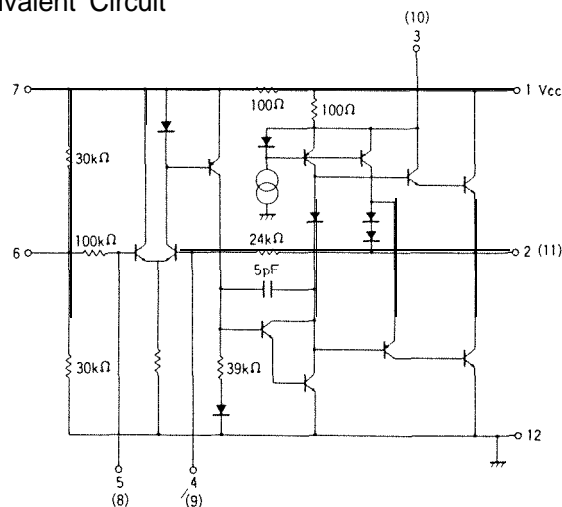

Fig. 3

### Absolute Maximum Ratings (Ta=25°C)

Parameter	Symbol	Limits	Unit
Supply voltage	V <sub>CC</sub>	18*	V
Power dissipation	P <sub>d</sub>	20**	W
Operating temperature range	T <sub>opr</sub>	-20~75	°C
Storage temperature range	T <sub>stg</sub>	-30~125	°C
Junction temperature	T <sub>j</sub>	150	°C

\* Under no signal \*\* Back-metal temperature 75°C

### Recommended Operating Conditions

Parameter	Symbol	Min. †	Typ. ‡	Max. ††	Unit
Supply voltage	V <sub>CC</sub>	- 5	12	15	V

### Electrical Characteristics (Ta=25°C, V<sub>CC</sub>=12V)

Parameter	Symbol	Min.	Typ.	Max.	Unit	Conditions
Quiescent current	I <sub>Q</sub>	20	40	70	mA	—
Closed loop voltage gain	G <sub>VC</sub>	43	46	49	dB	f=1kHz, V <sub>IN</sub> =-46dBm
Rated output power	P <sub>OUT1</sub>	4.0	5.0	—	W	f=1kHz, THD=10%, R <sub>L</sub> =3Ω
Rated output power	P <sub>OUT2</sub>	—	4.5	—	W	f=1kHz, THD=10%, R <sub>L</sub> =4Ω
Total harmonic distortion	THD	—	0.3	1.5	%	f=1kHz, P <sub>OUT</sub> =0.5W
Output noise voltage	V <sub>NO</sub>	—	0.6	3.5	mVrms	R <sub>G</sub> =10kΩ
Input impedance	R <sub>IN</sub>	50	100	—	kΩ	f=1kHz

### Electrical Characteristics (Ta=25°C, V<sub>CC</sub>=9V)

Parameter	Symbol	Min.	Typ.	Max.	Unit	Conditions
Quiescent current	I <sub>Q</sub>	15	35	70	mA	—
Closed loop voltage gain	G <sub>VC</sub>	43	46	49	dB	f=1kHz, V <sub>IN</sub> =-46dBm
Rated output power	P <sub>OUT1</sub>	2.2	2.8	—	W	f=1kHz, THD=10%, R <sub>L</sub> =3Ω
Rated output power	P <sub>OUT2</sub>	—	2.3	—	W	f=1kHz, THD=10%, R <sub>L</sub> =4Ω
Total harmonic distortion	THD	—	0.3	1.5	%	f=1kHz, P <sub>OUT</sub> =0.5W
Output noise voltage	V <sub>NO</sub>	—	0.6	3.5	mVrms	R <sub>G</sub> =10kΩ
Input Impedance	R <sub>IN</sub>	50	100	—	kΩ	f=1kHz, V <sub>IN</sub> =5mV

### Test Circuit

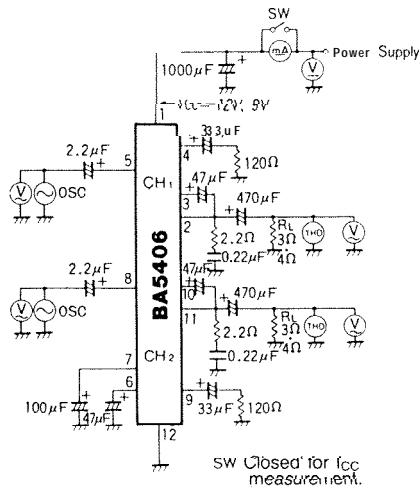

Fig. 4

### Application Example

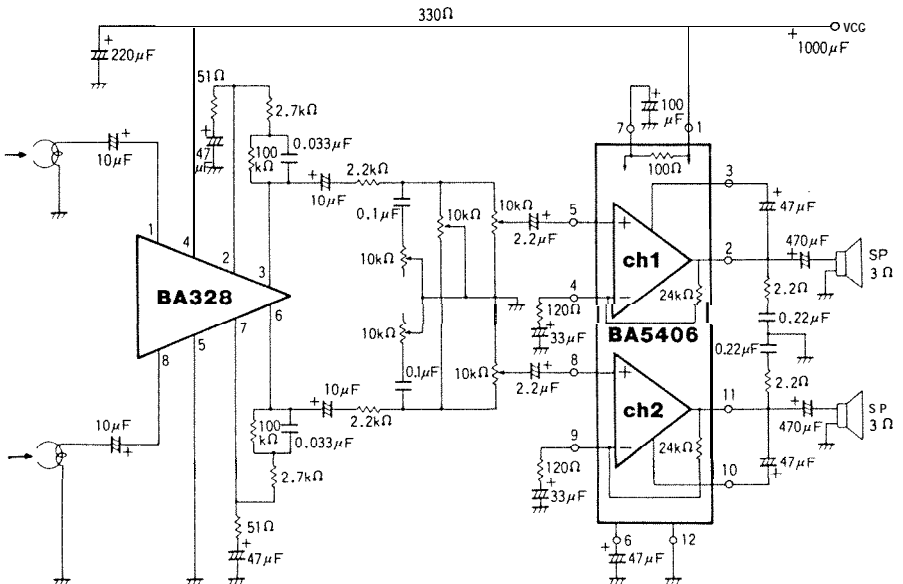

Fig. 5

# Electrical Characteristic Curves

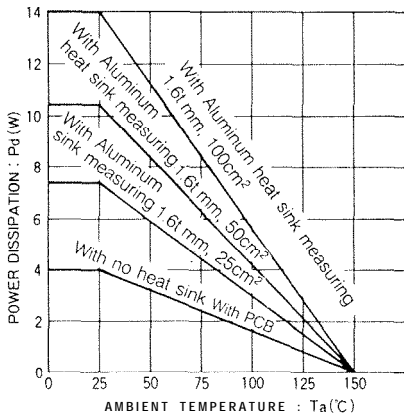

Fig 6 Thermal derating curves

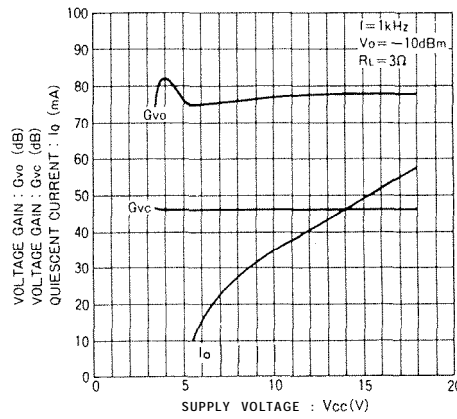

Fig. 7 Voltage gain/quiescent current vs. supply voltage

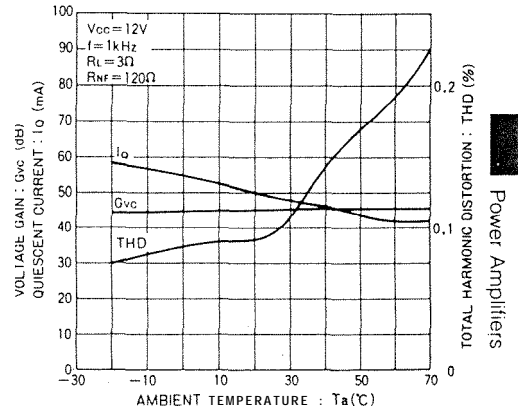

Fig. 8 Total harmonic distortion/voltage gain/quiescent current vs. ambient temperature

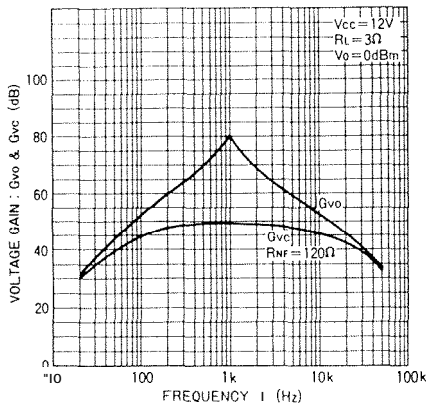

Fig. 9 Voltage gain vs. frequency

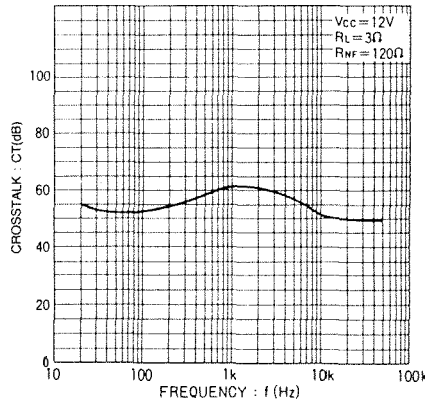

Fig. 10 Crosstalk vs. frequency

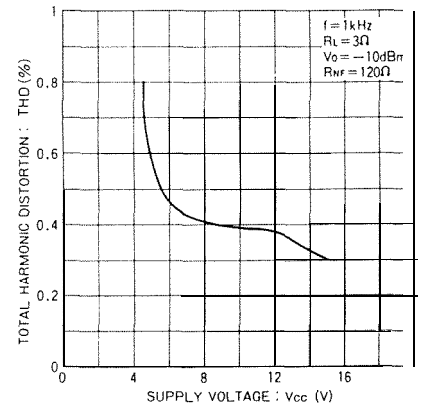

Fig. 11 Total harmonic distortion vs. supply voltage

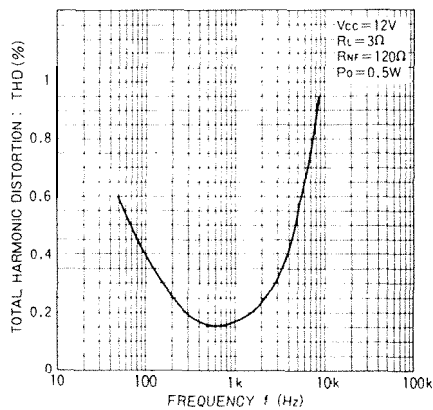

Fig. 12 Total harmonic distortion vs. frequency

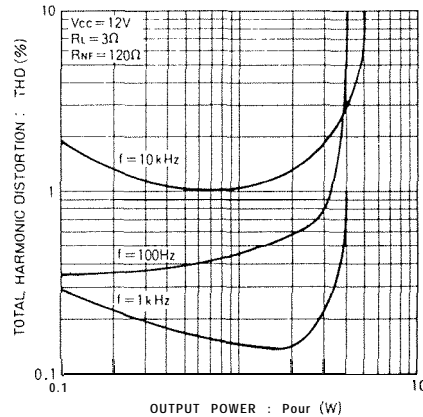

Fig. 13 Total harmonic distortion vs. output power

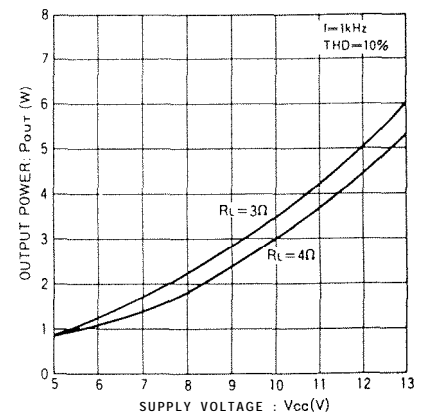

Fig. 14 Output power vs. supply voltage

# Electrical Characteristic Curves

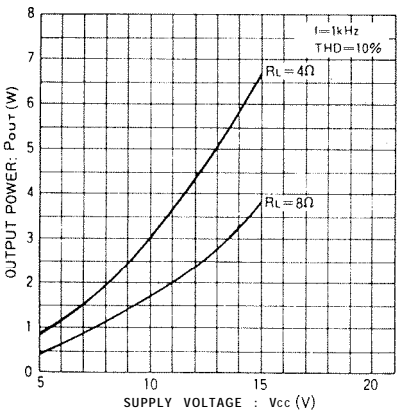

Fig. 15 Output power vs. supply voltage

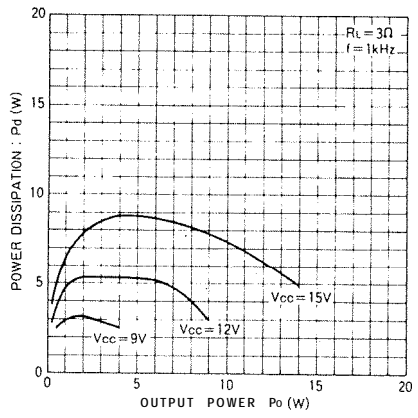

Fig. 16 Power dissipation vs. output power

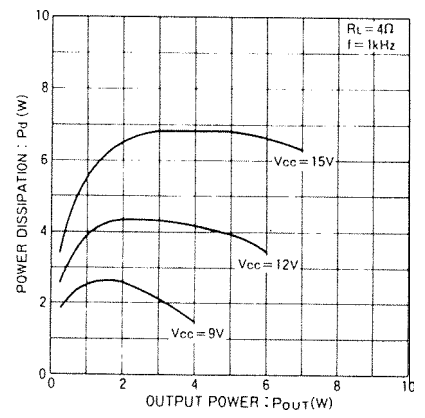

Fig. 17 Power dissipation vs. output power

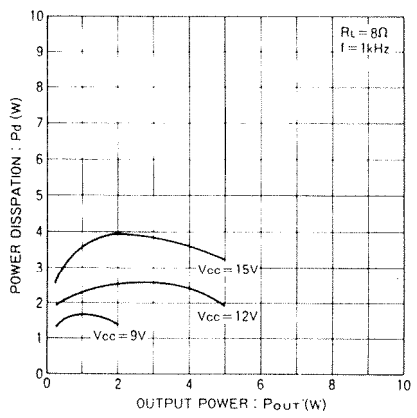

Fig. 18 Power dissipation vs. output power

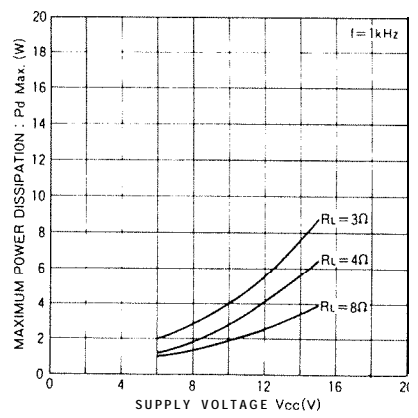

Fig. 19 Maximum power dissipation vs. supply voltage

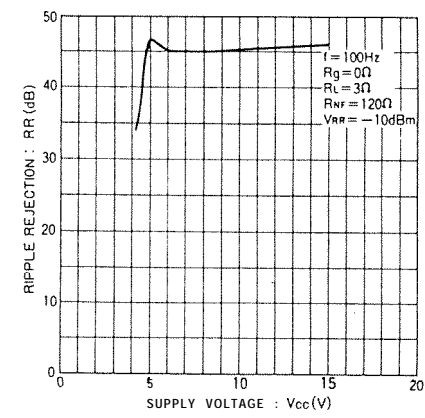

Fig. 20 Ripple rejection vs. supply voltage