

QUASAR ELECTRONICS KIT No. 1003

5 Watt ELECTRONIC SIREN

General Description

This is a powerful electronic siren with an impressive 5 Watt power output, very suitable for alarm systems, cars, motorbikes and security devices in general. It can operate from a car or motorbike battery from 6 to 12 VDC and draws about 1 A in its full output. The output signal is used to drive a suitable loud speaker or an inverted cone horn for greater efficiency.

Technical Specifications - Characteristics

Working voltage:.....6-12 VDC
Maximum current:.....1 A (at 12 V)
Output power:.....6 Watts
Output frequency:.....2 KHz
Output impedance:.....8-25 ohm

How it Works

The circuit basically consists of a multivibrator built around the two first transistors TR1 & TR2 which produces a tone of about 2 KHz. The signal from the output of the multivibrator is used to drive the input of the third transistor TR3 which is the signal preamplifier and then is fed to the base of the output transistor that will amplify it further to the full output power of approximately 5 Watts. The circuit is very simple but very efficient and as the various stages are very basic circuit building blocks there isn't much in it that could possibly go wrong.

Construction

First of all let us consider a few basics in building electronic circuits on a printed circuit board. The board is made of a thin insulating material clad with a thin layer of conductive copper that is shaped in such a way as to form the necessary conductors between the various components of the circuit. The use of a properly designed printed circuit board is very desirable as it speeds construction up considerably and reduces the possibility of making errors. Quasar Electronics Kit boards also come pre-drilled and with the outline of the components and their identification printed on the component side to make construction easier. To protect the board during storage from oxidation and assure it gets to you in perfect condition the copper is tinned during manufacturing and covered with a special varnish that protects it from getting oxidised and makes soldering easier. Soldering

the components to the board is the only way to build your circuit and from the way you do it depends greatly your success or failure. This work is not very difficult and if you stick to a few rules you should have no problems. The soldering iron that you use must be light and its power should not exceed the 25 Watts. The tip should be fine and must be kept clean at all times. For this purpose come very handy specially made sponges that are kept wet and from time to time you can wipe the hot tip on them to remove all the residues that tend to accumulate on it. DO NOT file or sandpaper a dirty or worn out tip. If the tip cannot be cleaned, replace it. There are many different types of solder in the market and you should choose a good quality one that contains the necessary flux in its core, to assure a perfect joint every time. DO NOT use soldering flux apart from that which is already included in your solder. Too much flux can cause many problems and is one of the main causes of circuit malfunction. If nevertheless you have to use extra flux, as it is the case when you have to tin copper wires, clean it very thoroughly after you finish your work. In order to solder a component correctly you should do the following:

- Clean the component leads with a small piece of emery paper.
- Bend them at the correct distance from the component body and insert the component in its place on the board.
- You may find sometimes a component with heavier gauge leads than usual, that are too thick to enter in the holes of the p.c. board. In this case use a mini drill to increase the diameter of the holes slightly. Do not make the holes too large as this is going to make soldering difficult afterwards.
- Take the hot iron and place its tip on the component lead while holding the end of the solder wire at the point where the lead emerges from the board. The iron tip must touch the lead slightly above the p.c. board.
- When the solder starts to melt and flow wait till it covers evenly the area around the hole and the flux boils and gets out from underneath the solder. The whole operation should not take more than 5 seconds. Remove the iron and leave the solder to cool naturally without blowing on it or moving the component. If everything was done properly the surface of the joint must have a bright metallic finish and its edges should be smoothly ended on the component lead and the board track. If the solder looks dull, cracked, or has the shape of a blob then you have made a dry joint and you should remove the solder (with a pump, or a solder wick) and redo it.
- Take care not to overheat the tracks as it is very easy to lift them from the board and break them.
- When you are soldering a sensitive component it is good practice to hold the lead from the component side of the board with a pair of long-nose pliers to divert any heat that could possibly damage the component.
- Make sure that you do not use more solder than it is necessary as you are running the risk of short-circuiting adjacent tracks on the board, especially if they are very close together.
- After finishing your work cut off the excess of the component leads and clean the board thoroughly with a suitable solvent to remove all flux residues that still remain on it.

As with any other project you should start soldering on the board the least heat sensitive components of the circuit and progressively add the most sensitive ones. Start from the connection pins, put in their places the resistors, the capacitors and finally the transistors which are the only components that being polarised have to be inserted the right way round and should not be overheated. The output transistor TR4 is a power transistor and when it works in full output it dissipates a lot of heat. In order to protect it from breakdown it is necessary to mount it on a heat sink that is included in your kit. First locate the hole for the mounting screw measure and carefully bend the leads in such a way as to be able to pass them through the holes of the board while mounting the transistor in a horizontal position. The heatsink has an elongated hole provided for the leads to pass through it. Smear the back of the transistor casing (where a little metallic surface shows) with a little silicon grease thermal transfer compound and place it on the heatsink. Pass the mounting screw through the hole of the transistor, the heatsink and the board and tighten it carefully. Make sure the leads protrude from the other side of the board and solder them carefully. With this operation you have concluded the building of your electronic siren. Check it again visually and if everything is OK connect a speaker across its output and power it up. A loud clear whistling of about 2 KHz should come from the speaker.

Adjustments

This kit does not need any adjustments, if you follow the building instructions.

Warning

Quasar Electronics kits are sold as stand alone training kits. If they are used as part of a larger assembly and any damage is caused, our company bears no responsibility.

While using electrical parts, handle power supply and equipment with great care, following safety standards as described by international specs and regulations.

If it does not work

Check the power supply to make sure there are at least 6 VDC across the circuit, and that the polarity is correct.

Make sure the transistors are in the right places and the right way round. It is very easy to confuse TR3 with TR1 & TR2 because they have similar cases.

See that the speaker is connected properly to the output.

Check your work for possible dry joints, bridges across adjacent tracks or soldering flux residues that usually cause problems.

If your project still fails to work, please contact us for information on our Get-You-Going service.

Electronic Diagram

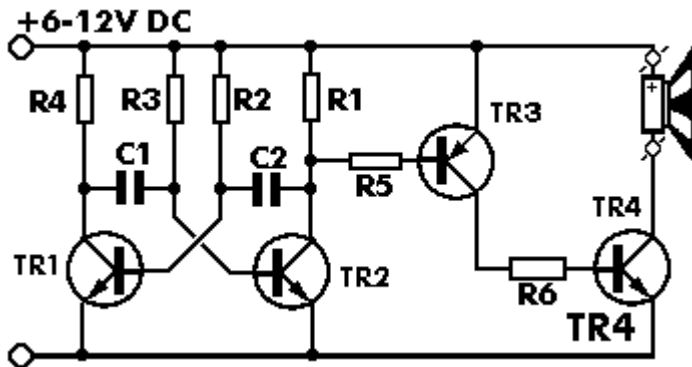

Parts List

All components including printed circuit board, assembly instructions including schematics and detailed parts list are supplied when you purchase the kit.

Ordering

For pricing info and online ordering please visit:

<http://www.quasarelectronics.com/1003.htm>

For further info please contact us by e-mail:

mailto: sales@QuasarElectronics.com

COPYRIGHT © 2003 Quasar Electronics Limited. All rights reserved. Reproduction of this document in whole or in part in any form or medium without express written permission of Quasar Electronics Limited is prohibited.

E&OE